

# Comments and Coordination Report

## Catfish Creek Road Bridge Rehabilitation Over Catfish Creek (Bridge No. 094026)

Highlands County, Florida

FDOT FPID No. 446394-1-54-01

HC Project No. 22061

Prepared for:



March 19, 2024

Kimley»Horn

# TABLE OF CONTENTS

I. Introduction .....	2
Project Description.....	2
Description of Alternatives .....	5
II. Project Kickoff.....	5
County Kick-off Meeting: August 23, 2023 .....	5
Public Involvement Plan.....	5
III. Public Meetings.....	8
Public Workshop: February 20, 2024 .....	8
IV. Agency and Stakeholder Coordination.....	10
SHPO Coordination .....	10

# FIGURES

Figure 1: Project Location Map .....	3
Figure 2: Project Schedule .....	4
Figure 3: Existing Conditions.....	6
Figure 4: Future Bridge Replacement (Unfunded).....	6
Figure 5: Alternative 1 – Interim Bridge .....	7
Figure 6: Alternative 2 – Interim Bridge .....	7
Figure 7: Alternative 3 – Interim Bridge .....	8
Figure 8: Alternative Preference.....	9
Figure 9: Comment Summary .....	9

# APPENDICES

- A: Public Workshop Notifications
- B: Public Workshop Materials
- C: Public Comments
- D: SHPO Correspondence

## I. INTRODUCTION

Highlands County is conducting a bridge rehabilitation project for Catfish Creek Road Bridge in Highlands County, Florida. The project location map, shown in **Figure 1**, illustrates the location and limits of the study.

The purpose of the project is to evaluate potential improvements to address existing structural maintenance requirements, as well as identify needs for enhancing safety, accommodating pedestrians and bicyclists, and meeting future transportation demand.

The purpose of this report is to document the public and agency participation accomplished throughout the study process. In compliance with State and Federal rules, a Public Involvement Program was developed and implemented as an integral part of this project. Highlands County recognizes that the success of any transportation improvement is dependent upon a comprehensive public outreach effort. The program focused on soliciting community participation regarding local issues and concerns throughout the project development process. The balance of this report describes the following components of the project: public communications (emails, newsletters, website, media coverage, etc.), public workshop, and agency coordination. The project schedule is shown in Error! Reference source not found..

### Project Description

Highlands County is conducting a bridge rehabilitation project to evaluate Catfish Creek Road Bridge in Highlands County, Florida (see **Figure 1**). The existing bridge over Catfish Creek has two narrow travel lanes without shoulders or sidewalks. This project will seek to rehabilitate the existing bridge, as well as identify ways to enhance safety, accommodate pedestrians and cyclists, and meet future travel demand.

Figure 1: Project Location Map

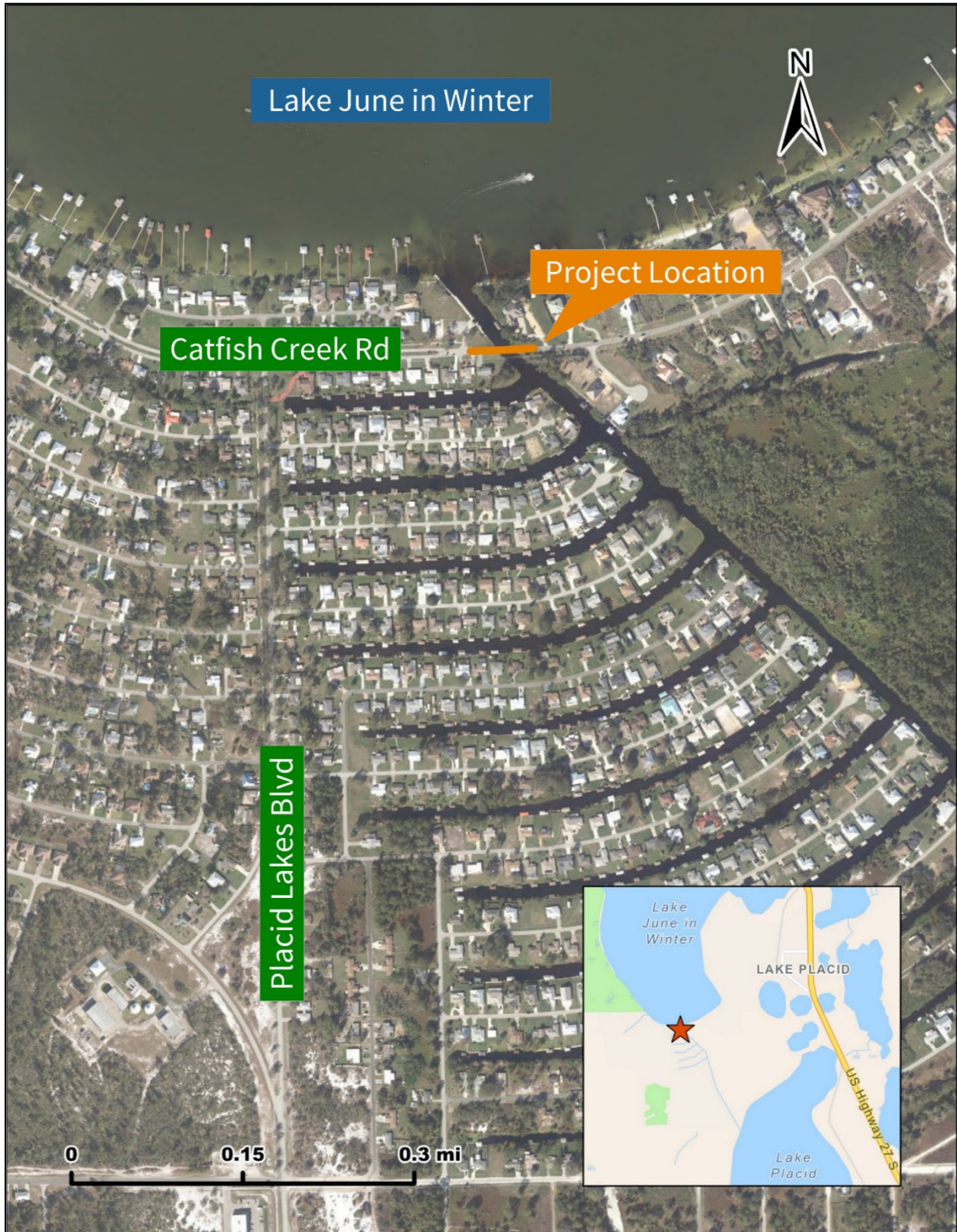

**Figure 2: Project Schedule**

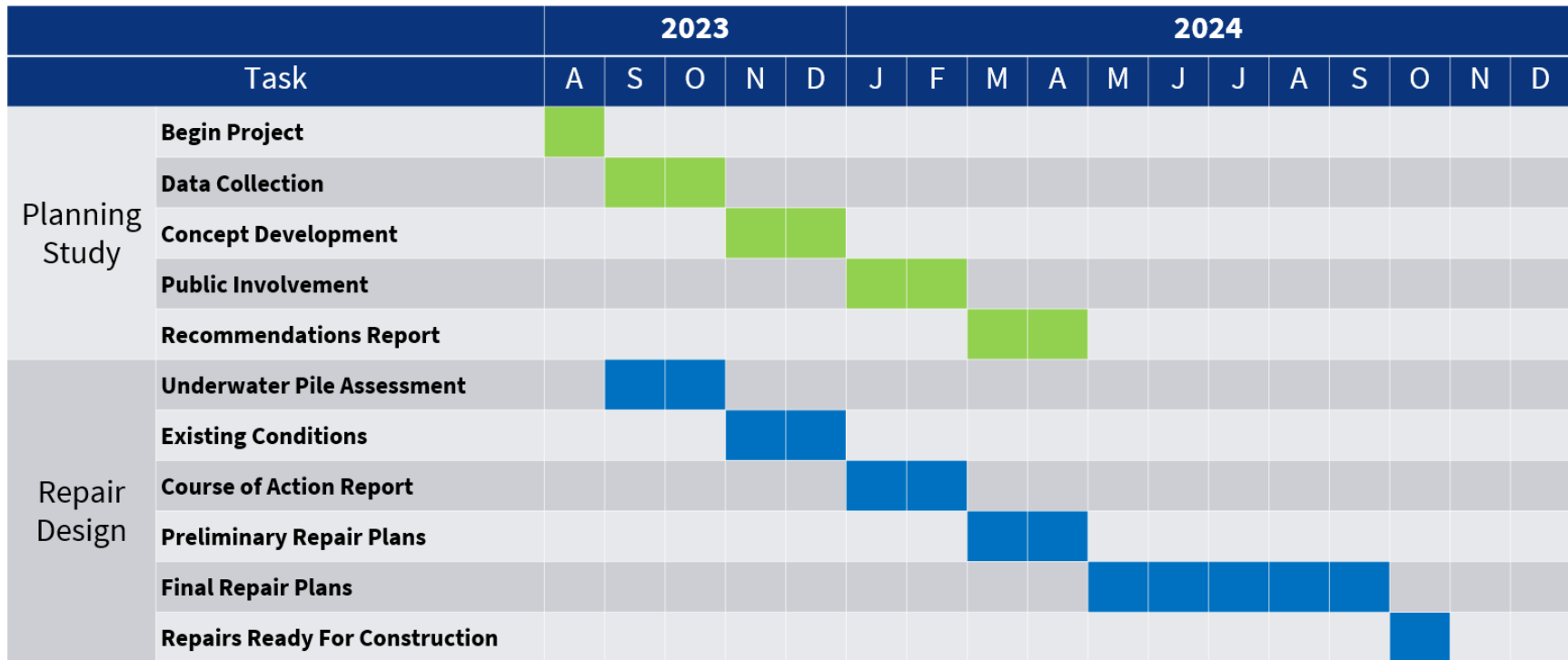

## Project Status

The project is identified in the Heartland Regional TPO's Transportation Improvement Program (TIP) and Florida Department of Transportation's (FDOT) Five Year Work Program and is funded for construction in Fiscal Year 2024 (FPID 446394-1).

## Description of Alternatives

The existing bridge has two 9-foot travel lanes in each direction, but no shoulders, bike lanes, or sidewalks (see **Figure 3**). Four bridge typical sections were presented to the public, along with the existing (no-build) alternative:

- **Figure 4: Future Bridge Replacement (Unfunded)**
- **Figure 5: Alternative 1 – Interim Bridge**
- **Figure 6: Alternative 2 – Interim Bridge**
- **Figure 7: Alternative 3 – Interim Bridge**

## II. PROJECT KICKOFF

### County Kick-off Meeting: August 23, 2023

Highlands County and Kimley-Horn staff had a kick-off meeting on August 23, 2023 to initiate the project and discuss project schedule.

### Public Involvement Plan

A Public Involvement Plan (PIP) prepared under separate cover (November 2023) was created for this project outlining community outreach efforts. It presents the approach used to involve the public, public officials, the media, and government agencies throughout the project. A property owner mailing list was developed for mailing of newsletters and public meeting invitations. A public officials mailing list was also developed to notify representatives in the project area with newsletters and meeting and hearing invitations.

**Figure 3: Existing Conditions**

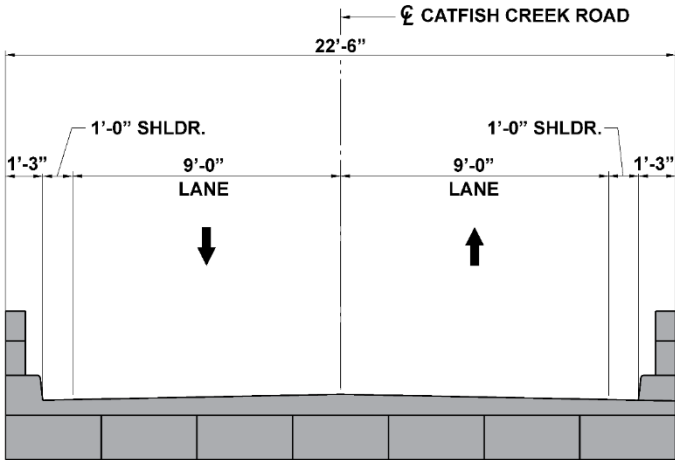

**Figure 4: Future Bridge Replacement (Unfunded)**

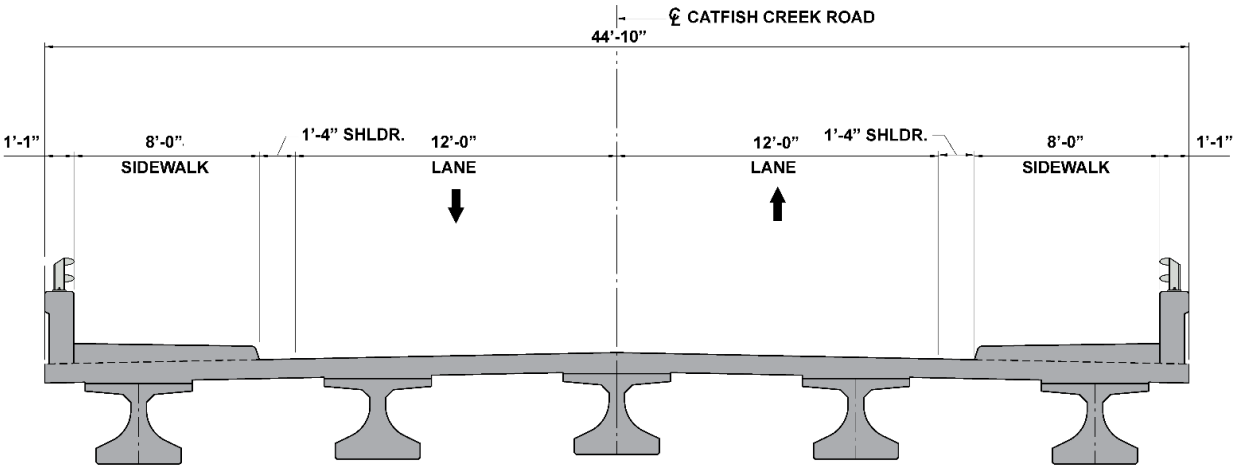

**Figure 5: Alternative 1 – Interim Bridge**

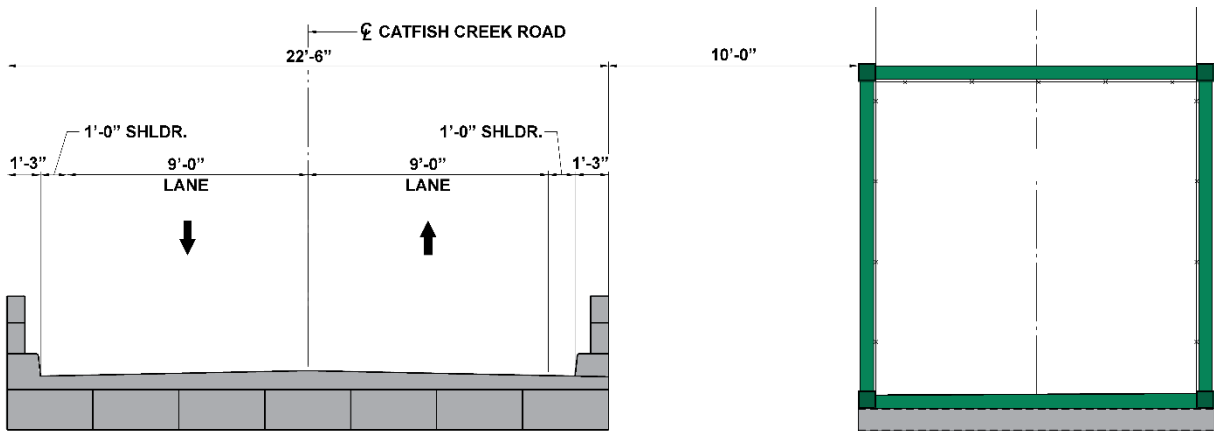

**Figure 6: Alternative 2 – Interim Bridge**

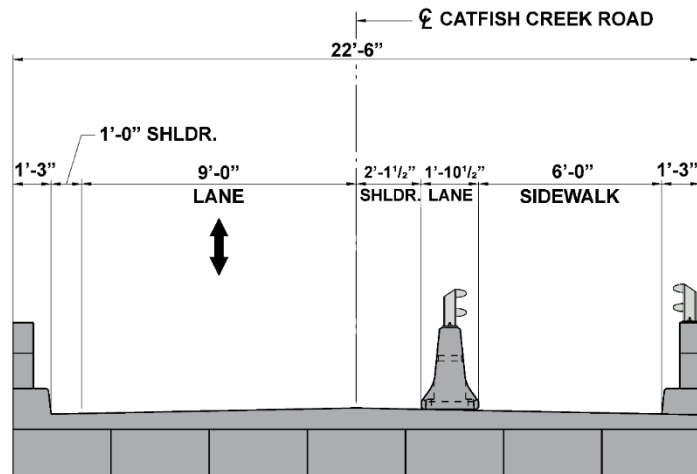

**Figure 7: Alternative 3 – Interim Bridge**

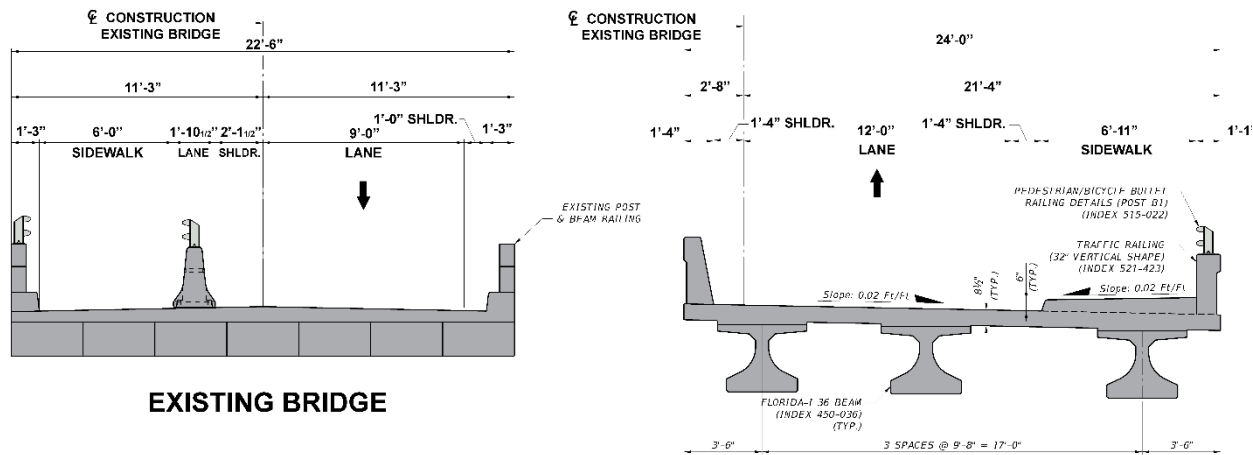

### III. PUBLIC MEETINGS

#### Public Workshop: February 20, 2024

Highlands County held a Public Workshop on February 20, 2024, from 6:30 p.m. to 8:00 p.m. at Placid Lakes Home & Property Owners Association Clubhouse, 2010 Placid Lakes Boulevard, Lake Placid, Florida 33852. The meeting introduced the project and the study process.

Highlands County distributed notification emails to public officials and individuals interested in the project on January 23, 2024. Notices were mailed to property owners and tenants located within at least 300 feet of the study corridor and in surrounding neighborhoods. Notice was published in the Florida Administrative Register (FAR) and the Highlands News-Sun on February 12, 2024, and February 13, 2024, respectively. Notification emails, advertisements, screenshot of online announcements, press release, mailing list, and newsletter invite can be found in **Appendix A**.

A total of 51 members of the public and no elected officials signed in at the public meeting. At this public workshop, Highlands County displayed information about the proposed project for public review and input on the study in general, the study's schedule, and a preview of the next steps to be taken. Display boards on site included an overview of the project schedule, a description of the alternatives being considered, and the overall project schedule.

The meeting was conducted in a question-and-answer format, allowing attendees to ask questions and provide comments to Highlands County representatives in a group setting. These comments were informal and are not included in the project record. Additional comments were solicited at the meeting via written comment form. Contact information was provided to submit written comments after the meeting.

Attendees were provided with a one-page handout. Attendees provided 10 comments, which generally expressed concerns for the current condition of the bridge and support for a new bridge in the future. The sign-in sheets, meeting handout, and comment sheets, as well as those received in the 10 days following, can be found in **Appendix B**.

16 total comments were received between the Public Workshop and email correspondence. Most of the comments did not state an alternative preference, but support was strong for a bridge replacement (**Figure 8**). A summary of the comments is shown in **Figure 9**. No comments expressed concern with regards to the potential one-lane two-way operation of the bridge shown in Alternative 2.

**Figure 8: Alternative Preference**

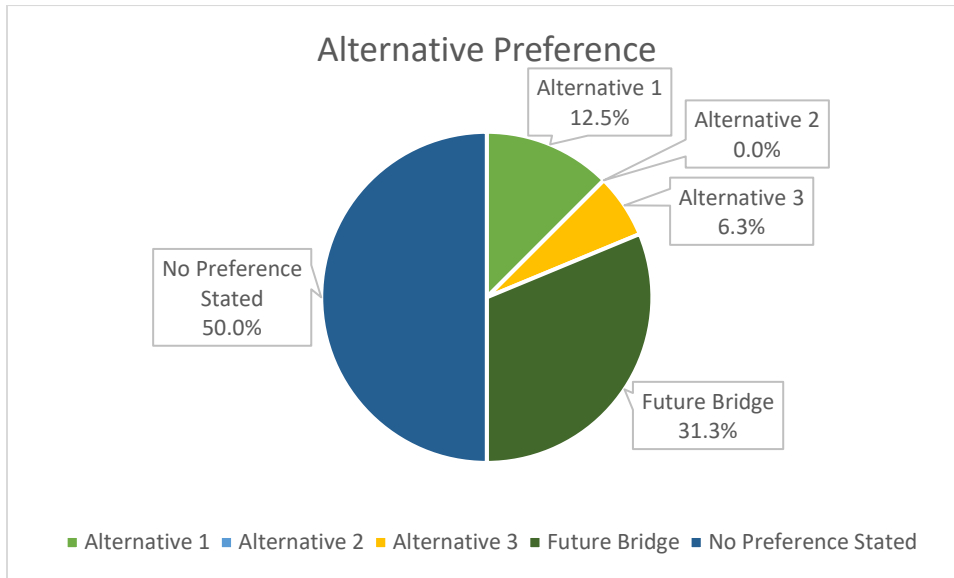

**Figure 9: Comment Summary**

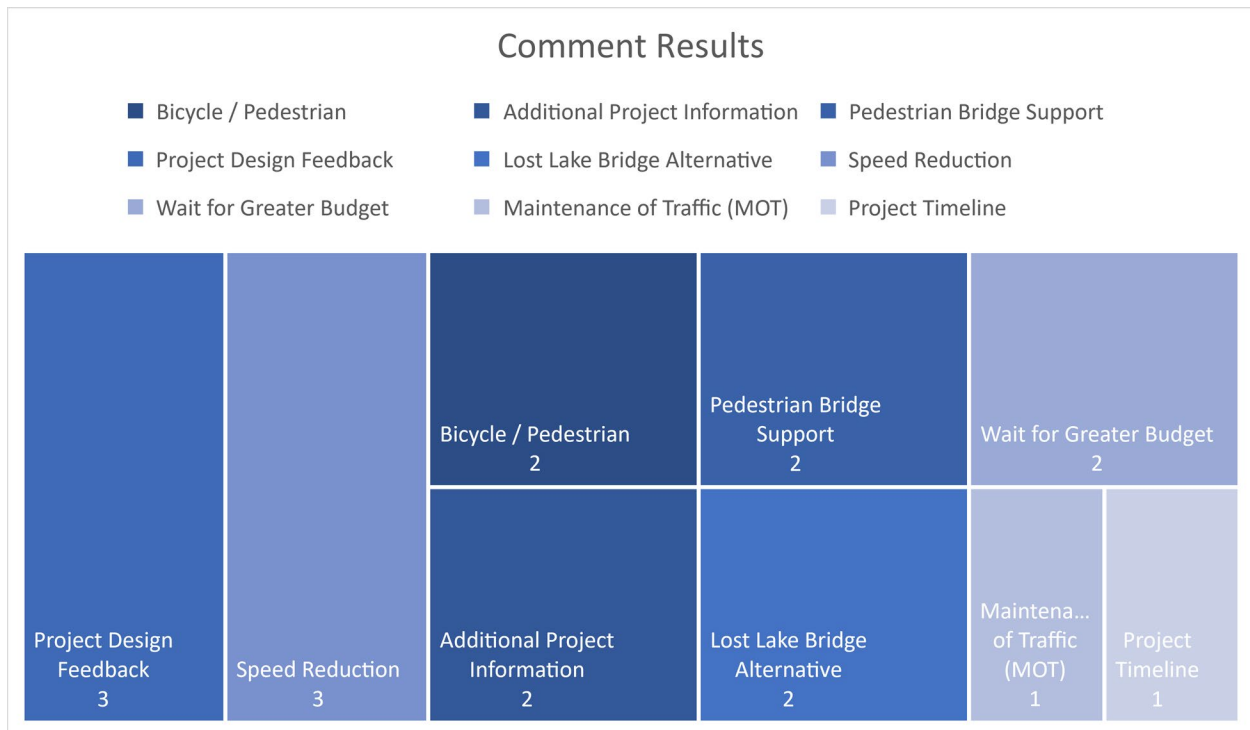

## IV. AGENCY AND STAKEHOLDER COORDINATION

### SHPO Coordination

A request for any known resources within a 0.25-mile buffer of the Catfish Creek Road bridge was submitted to the State Historic Preservation Office (SHPO). An archaeological site was reported just east of the bridge (see **Appendix D**). Due to the presence of this site, a Cultural Resource Assessment Report (CRAS) will be completed during a future phase of the project.

## **APPENDIX A**

### Public Workshop Notifications

## Eaton, Shayna

---

**From:** Clogston, Karen V. <kclogston@highlandsfl.gov>  
**Sent:** Tuesday, January 23, 2024 12:11 PM  
**To:** Clogston, Karen V.  
**Cc:** Langford, James D.; DeFronzo II, Joseph L.; Linsinbigler, Vickey; Howerton Jr, Clinton; Willis, Jennifer; Culpepper, Melony; Attinger, Philip; Oujevolk, Richard M.  
**Subject:** \*\*\*DO NOT REPLY ALL\*\*\* Public Workshop scheduled for Catfish Creek Road Bridge Rehabilitation, FPID No. 446394-1-54-01 & HC Project No. 22061, Highlands County CatfishCreek\_PropOwner.pdf  
**Attachments:**  
**Categories:** External

Some people who received this message don't often get email from kclogston@highlandsfl.gov. [Learn why this is important](#)

Highlands County invites you to a Public Workshop for the Catfish Creek Road Bridge Rehabilitation Project along Catfish Creek Road over Catfish Creek.

This project will evaluate potential improvements to address existing structural maintenance requirements, as well as identify needs for enhancing safety, accommodating pedestrians and bicyclists, and meeting future transportation demand. **Please see the newsletter attached to this email.**

The Public Workshop is being conducted to involve the public, local officials, and interested agencies in the project development process and to inform interested parties of the project's current status.

### **IN-PERSON WORKSHOP:**

Tuesday, February 20, 2024  
6:30 p.m. – 8 p.m. open house  
Placid Lakes Home & Property Owners Association Clubhouse  
2010 Placid Lakes Blvd  
Lake Placid, FL 33852

**If you are unable to attend the meeting,** comments can also be provided by email (ROujevolk@HighlandsFL.gov) or mail (Highlands County Engineering, Attn: Richard "OJ" Oujevolk, 505 South Commerce Ave, Sebring, FL 33870). While comments about the project are accepted at any time, they must be received or postmarked by March 1, 2024, to be included in the formal workshop record. Questions can be answered by emailing the Highlands County project manager Richard "OJ" Oujevolk at ROujevolk@HighlandsFL.gov.

Highlands County is sending notices to property owners, business owners, interested persons and organizations within 300 feet of the project to provide the opportunity to give comments regarding this project (*see the attached newsletter*).

Public participation is solicited without regard to race, color, national origin, age, sex, religion, disability or family status. Persons who require special accommodations under the Americans with Disabilities Act should contact Sherri Bennett, Highlands County ADA Coordinator, by phone at (863) 402-6509 or by email at HRManager@HighlandsFL.gov at least five (5) days prior to the meeting. Persons who require translation services (free of charge) should contact Emanuelle Rodriguez at (386) 271-0273 or email at emanuelle.rodriguez@kimley-horn.com at least five (5) days prior to the meeting.



# Catfish Creek Rd



**Karen Clogston, APIO**

Public Information Officer  
Highlands County Board of County Commissioners  
863-402-6636  
[kclogston@highlandsfl.gov](mailto:kclogston@highlandsfl.gov)  
[www.highlandsfl.gov](http://www.highlandsfl.gov)



600 S. Commerce Ave., Sebring FL 33870

DISCLAIMER: Under Florida law, e-mail addresses are public records. If you do not want your e-mail address or mail to this entity. Instead contact this office by phone or in writing (pursuant to Section 668.6076, Florida Statutes).

## Notice of Meeting/Workshop Hearing

### OTHER AGENCIES AND ORGANIZATIONS

#### Kimley-Horn and Associates, Inc.

The County of Highlands announces a workshop to which all persons are invited.

DATE AND TIME: Tuesday, February 20, 2024, 6:30 p.m. – 8:00 p.m.

PLACE: Placid Lakes Home & Property Owners Association Clubhouse, 2010 Placid Lakes Blvd, Lake Placid, FL 33852

GENERAL SUBJECT MATTER TO BE CONSIDERED: Highlands County invites you to a Public Workshop for the Catfish Creek Road Bridge Rehabilitation Project along Catfish Creek Road over Catfish Creek.

This project will evaluate potential improvements to address existing structural maintenance requirements, as well as identify needs for enhancing safety, accommodating pedestrians and bicyclists, and meeting future transportation demand.

The Public Workshop is being conducted to present information about the preliminary alternatives and provides the opportunity for the public to express their views about the project.

#### IN-PERSON WORKSHOP:

Tuesday, February 20, 2024, 6:30 p.m. – 8:00 p.m. open house

Placid Lakes Home & Property Owners Association Clubhouse, 2010 Placid Lakes Blvd, Lake Placid, FL 33852

This will include a looping video (no formal presentation) and the project team will be available for discussion.

If you are unable to attend the meeting, comments can also be provided email (ROujevolk@HighlandsFL.gov) or mail (Highlands County Engineering, Attn: Richard “OJ” Oujevolk, 505 South Commerce Ave, Sebring, FL 33875).

While comments about the project are accepted at any time, they must be received or postmarked by March 1, 2024, to be included in the formal workshop record. Questions can be answered by emailing the Highlands County project manager Richard “OJ” Oujevolk at ROujevolk@HighlandsFL.gov.

A summary of the workshop will be available on the webpage approximately 30 days following the close of the comment period.

Highlands County is sending notices to property owners, business owners, interested persons and organizations within 300 feet of the project to provide the opportunity to give comments to Highlands County regarding this project.

A copy of the agenda may be obtained by contacting: N/A

Pursuant to the provisions of the Americans with Disabilities Act, any person requiring special accommodations to participate in this workshop/meeting is asked to advise the agency at least 5 days before the workshop/meeting by contacting: Sherri Bennett, Highlands County ADA Coordinator, by phone at (863)402-6509 or by email at HRManager@HighlandsFL.gov. If you are hearing or speech impaired, please contact the agency using the Florida Relay Service, 1(800)955-8771 (TDD) or 1(800)955-8770 (Voice).

For more information, you may contact: Richard “OJ” Oujevolk at ROujevolk@HighlandsFL.gov



February 20 6:30 at Community Center!!

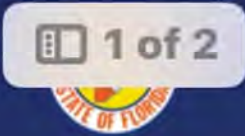

### Catfish Creek Road Bridge Rehabilitation

Along Catfish Creek Road over Catfish Creek

January 2024

FPID Number: 446394-1-54-01

HC Project Number: 22061

#### PUBLIC WORKSHOP

Highlands County invites you to attend a Public Workshop on February 20, 2024 for the Catfish Creek Road Bridge Rehabilitation project.

This Public Workshop is being conducted to involve the public, local officials, and interested agencies in the project development process and to inform interested parties of the project's current status.

#### LIVE IN-PERSON WORKSHOP:

Tuesday, February 20, 2024

6:30 p.m. - 8 p.m. Open House

Placid Lakes Home & Property Owners Association Clubhouse  
2010 Placid Lakes Blvd  
Lake Placid, FL 33852



Catfish Creek Road bridge looking east.

#### Project Overview

The existing bridge over Catfish Creek (shown in the photo) has two narrow travel lanes without shoulders or sidewalks. This project will seek to rehabilitate the existing bridge as well as identify ways to:

- Enhance safety
- Accommodate pedestrians and cyclists
- Meet future travel demand



# Placid Lakes Home & Property Owners Association

February 19 at 7:00 PM · 🌐

...

Tuesday at 6:30 be there!! Let's show them how much our community supports doing something about that dangerous bridge!



## Catfish Creek Road Bridge Rehabilitation

Along Catfish Creek Road over Catfish Creek

January 2024

FPID Number: 446394-1-54-01

HC Project Number: 22061

### PUBLIC WORKSHOP

Highlands County invites you to attend a Public Workshop on February 20, 2024 for the Catfish Creek Road Bridge Rehabilitation project.

This Public Workshop is being conducted to involve the public, local officials, and interested agencies in the project development process and to inform interested parties of the project's current status.

#### LIVE IN-PERSON WORKSHOP:

Tuesday, February 20, 2024  
6:30 p.m. - 8 p.m. Open House

Placid Lakes Home & Property Owners Association Clubhouse  
2010 Placid Lakes Blvd  
Lake Placid, FL 32852



Catfish Creek Road bridge looking east.

### Project Overview

The existing bridge over Catfish Creek (shown in the photo) has two narrow travel lanes without shoulders or sidewalks. This project will seek to rehabilitate the existing bridge as well as identify ways to:

- Enhance safety
- Accommodate pedestrians and cyclists
- Meet future travel demand



For Immediate Release  
February 13, 2024

Karen Clogston, APIO, (863) 402-6833  
KClogston@HighlandsFL.gov

**Public Workshop for  
Catfish Creek Road Bridge Rehabilitation**  
*In-Person: Anytime between 6:30 p.m. – 8 p.m. on February 20, 2024*

**Highlands County, Florida** – Highlands County invites you to a Public Workshop for the Catfish Creek Road Bridge Rehabilitation project (FPID No. 446394-1-54-01 & HC Project No. 22061) along Catfish Creek Road over Catfish Creek (Bridge No. 094026). The Public Workshop is being conducted to involve the public, local officials, and interested agencies in the project development process and to inform interested parties of the project's current status.

Attend the public workshop:

Tuesday, February 20, 2024  
Placid Lakes Home & Property Owners  
Association Clubhouse  
2010 Placid Lakes Blvd  
Lake Placid, FL 33852  
6:30 p.m. – 8 p.m.

If you are unable to attend the meeting, comments can be provided by email (ROujevolk@HighlandsFL.gov) or mail (Highlands County Engineering, Attn: Richard "OJ" Oujevolk, 505 South Commerce Ave, Sebring, FL 33870). While comments about the project are accepted at any time, they must be received or postmarked by March 1, 2024, to be included in the formal workshop record. Questions can be answered by emailing the Highlands County project manager Richard "OJ" Oujevolk at ROujevolk@HighlandsFL.gov.

Highlands County is sending notices to property owners, business owners, interested persons and organizations within 300 feet of the project to provide the opportunity to give comments regarding this project (*see the attached newsletter*). Public participation is solicited without regard to race, color, national origin, age, sex, religion, disability or family status. Persons who require special accommodations under the Americans with Disabilities Act should contact Sherri Bennett, Highlands County ADA Coordinator, by phone at (863) 402-6509 or by email at [HRManager@HighlandsFL.gov](mailto:HRManager@HighlandsFL.gov) at least five (5) days prior to the meeting. Persons who require translation services (free of charge) should contact Emanuelle Rodriguez at (386) 271-0273 or email at [emanuelle.rodriguez@kimley-horn.com](mailto:emanuelle.rodriguez@kimley-horn.com) at least five (5) days prior to the meeting.

###

NAME 1	NAME 2	ADDRESS 1	ADDRESS 2
4 ACE HOLDINGS LLC		9785 SW 60TH ST	MIAMI, FL 33173
ANDERSON ROBERT S +	WOODWARD CARRIE A	491 BARBRI LN	DAVIE, FL 33325
ARISTIZABAL RAMIRO + MAGDA		100 MAR BET DRIVE	LAKE PLACID, FL 33852
ASHER JOHN M + STEPHANIE		12936 BLISS LOOP	BRADENTON, FL 34211
BAKER JOHN H E II + KAREN A		16264 122ND DR N	JUPITER, FL 334783
BIAGIOTTI SOFIA H		532 CATFISH CREEK RD	LAKE PLACID, FL 33852
BONICATTO DANIEL + HANNAH TRS		101 LAKEFRONT CT NE	LAKE PLACID, FL 33852
BOWEN FREDERICK A TRUST		364 CATFISH CREEK RD	LAKE PLACID, FL 33852
BOWES BRETT S + JULIE A		306 NIPPENOSE RD	JERSY SHORE, PA 17740
BOWES LYNN S TRUST		108 LAKEFRONT CT NE	LAKE PLACID, FL 33852
BUTTRILL FAMILY REVOCABLE TRUST	BUTTRILL DULCE M TRUSTEE	124 ORANGE RD NE	LAKE PLACID, FL 33852
CASSIDY BRIAN J + EUGENIA		11725 SW 59TH CT	COOPER CITY, FL 33330
CASTALINE T M + MICHELLE L TRUSTEES		248 CUMQUAT RD NE	LAKE PLACID, FL 33852
CLAIRE EARL J + SALLY S		403 CATFISH CREEK RD	LAKE PLACID, FL 33852
CODY WILLIAM D JR + DENA M		9764 E TREE TOPS CT	DAVIE, FL 33328
COLLINS DAROL TRUST		110 ORANGE RD NE	LAKE PLACID, FL 33852
CRUZ FRANCISCO + SONIA		105 LAKEFRONT CT NE	LAKE PLACID, FL 33852
CURRENT OCCUPANT		100 TUOMEY CT	LAKE PLACID, FL 33852
CURRENT OCCUPANT		101 ORANGE RD NE	LAKE PLACID, FL 33852
CURRENT OCCUPANT		102 ORANGE RD NE	LAKE PLACID, FL 33852
CURRENT OCCUPANT		103 LAKEFRONT CT NE	LAKE PLACID, FL 33852
CURRENT OCCUPANT		104 LAKEFRONT CT NE	LAKE PLACID, FL 33852
CURRENT OCCUPANT		104 TUOMEY CT	LAKE PLACID, FL 33852
CURRENT OCCUPANT		105 ORANGE RD NE	LAKE PLACID, FL 33852
CURRENT OCCUPANT		106 LAKEFRONT CT NE	LAKE PLACID, FL 33852
CURRENT OCCUPANT		106 ORANGE RD NE	LAKE PLACID, FL 33852
CURRENT OCCUPANT		107 LAKEFRONT CT NE	LAKE PLACID, FL 33852
CURRENT OCCUPANT		108 TUOMEY CT	LAKE PLACID, FL 33852
CURRENT OCCUPANT		109 LAKEFRONT CT NE	LAKE PLACID, FL 33852
CURRENT OCCUPANT		109 ORANGE RD NE	LAKE PLACID, FL 33852
CURRENT OCCUPANT		112 LAKEFRONT CT NE	LAKE PLACID, FL 33852
CURRENT OCCUPANT		112 ORANGE RD NE	LAKE PLACID, FL 33852
CURRENT OCCUPANT		112 TUOMEY CT	LAKE PLACID, FL 33852
CURRENT OCCUPANT		114 LAKEFRONT CT NE	LAKE PLACID, FL 33852
CURRENT OCCUPANT		115 ORANGE RD NE	LAKE PLACID, FL 33852
CURRENT OCCUPANT		116 TUOMEY CT	LAKE PLACID, FL 33852
CURRENT OCCUPANT		117 ORANGE RD NE	LAKE PLACID, FL 33852
CURRENT OCCUPANT		120 TUOMEY CT	LAKE PLACID, FL 33852
CURRENT OCCUPANT		121 ORANGE RD NE	LAKE PLACID, FL 33852
CURRENT OCCUPANT		123 ORANGE RD NE	LAKE PLACID, FL 33852
CURRENT OCCUPANT		124 TUOMEY CT	LAKE PLACID, FL 33852
CURRENT OCCUPANT		125 ORANGE RD NE	LAKE PLACID, FL 33852
CURRENT OCCUPANT		126 ORANGE RD NE	LAKE PLACID, FL 33852

NAME 1	NAME 2	ADDRESS 1	ADDRESS 2
CURRENT OCCUPANT		127 ORANGE RD NE	LAKE PLACID, FL 33852
CURRENT OCCUPANT		128 TUOMEY CT	LAKE PLACID, FL 33852
CURRENT OCCUPANT		129 ORANGE RD NE	LAKE PLACID, FL 33852
CURRENT OCCUPANT		130 ORANGE RD NE	LAKE PLACID, FL 33852
CURRENT OCCUPANT		131 ORANGE RD NE	LAKE PLACID, FL 33852
CURRENT OCCUPANT		363 CATFISH CREEK RD	LAKE PLACID, FL 33852
CURRENT OCCUPANT		367 CATFISH CREEK RD	LAKE PLACID, FL 33852
CURRENT OCCUPANT		375 CATFISH CREEK RD	LAKE PLACID, FL 33852
CURRENT OCCUPANT		407 CATFISH CREEK RD	LAKE PLACID, FL 33852
CURRENT OCCUPANT		411 CATFISH CREEK RD	LAKE PLACID, FL 33852
CURRENT OCCUPANT		415 CATFISH CREEK RD	LAKE PLACID, FL 33852
CURRENT OCCUPANT		419 CATFISH CREEK RD	LAKE PLACID, FL 33852
CURRENT OCCUPANT		423 CATFISH CREEK RD	LAKE PLACID, FL 33852
CURRENT OCCUPANT		427 CATFISH CREEK RD	LAKE PLACID, FL 33852
CURRENT OCCUPANT		431 CATFISH CREEK RD	LAKE PLACID, FL 33852
CURRENT OCCUPANT		435 CATFISH CREEK RD	LAKE PLACID, FL 33852
CURRENT OCCUPANT		439 CATFISH CREEK RD	LAKE PLACID, FL 33852
CURRENT OCCUPANT		443 CATFISH CREEK RD	LAKE PLACID, FL 33852
CURRENT OCCUPANT		500 CATFISH CREEK RD	LAKE PLACID, FL 33852
CURRENT OCCUPANT		501 CATFISH CREEK RD	LAKE PLACID, FL 33852
CURRENT OCCUPANT		504 CATFISH CREEK RD	LAKE PLACID, FL 33852
CURRENT OCCUPANT		508 CATFISH CREEK RD	LAKE PLACID, FL 33852
CURRENT OCCUPANT		516 CATFISH CREEK RD	LAKE PLACID, FL 33852
CURRENT OCCUPANT		520 CATFISH CREEK RD	LAKE PLACID, FL 33852
DASILVA KENNETH + CHERYL A TRUSTEES + DIAZ MAYRA +	BURWELL FLOYD S JR + CRISTINA M TRUSTEES	6350 SW 58TH CT	DAVIE, FL 33314
DOBBINS ALAN DERRY +	TORERO MARCUS	1252 ELDER AV	BRONX, NY 10472
DOOLEY EDIE R +	SIGALA SHIRLEY DIANE	2215 PASEO DE LAS AMERICAS STE 25-BOX 103	SAN DIEGO, CA 92154
DOWLER GLENN TRUST +	MUNIZ SUSAN R	210 15TH ST SW	NAPLES, FL 34117
EARNSHAW PHILIP + JANET	DOWLER SHANNON J TRUST	15595 HAWKER LN	WELLINGTON, FL 33414
ENRIGHT DONALD P + BARBARA J		424 CATFISH CREEK RD	LAKE PLACID, FL 33852
FABIK EDWARD A + PAULA R TRS		378 CATFISH CREEK RD	LAKE PLACID, FL 33852
FUCHS J A + DONNA E TRUSTEES		120 ORANGE RD NE	LAKE PLACID, FL 33852
GARY KAREN SUE		856 NW 164 AV	PEMBROKE PINES, FL 33028
GIROLAMO DIANE M DI		112 WILD TURKEY RUN	WHITELAND, IN 46184
GUNTHER CARL F + MARY L		62 FOREST ST	WILMINGTON, MA 1887
HERNANDES REAL EST HOLDINGS LLC		414 CATFISH CREEK RD	LAKE PLACID, FL 33852
HOADLEY ROBERT F JR + RACHELLE M TR		3305 NW 79TH AV	MIAMI, FL 33122
HONKALA SCOTT R + SONJA A TRUSTS		100 ORANGE RD NE	LAKE PLACID, FL 33852
HOWARD THOMAS L +	HART-HOWARD JESSICA D	581 NH RT 119	RINDGE, NH 3461
HOY MARIE-CLAIRE F TRS		374 CATFISH CREEK RD	LAKE PLACID, FL 33852
HUDSON MICHAEL J +		104 ORANGE RD NE	LAKE PLACID, FL 33852
JOSEF DIETER A + SALLYANN	PANACKIA CHARLES R	113 LAKEFRONT CT NE	LAKE PLACID, FL 33852
		14206 ASTER AV	WELLINGTON, FL 33414

NAME 1	NAME 2	ADDRESS 1	ADDRESS 2
KLINE W SCOTT		103 ORANGE RD NE	LAKE PLACID, FL 33852
KYZER DONALD R		540 CATFISH CREEK RD	LAKE PLACID, FL 33852
LAURENCE L E + LINDA A TRUSTEES		1 ROSEWOOD DR S	LAKE PLACID, FL 33852
MATHEWS MICHAEL L TRUSTEE		115 LAKEFRONT CT NE	LAKE PLACID, FL 33852
MATTHEWS CURT J + MISTY D		102 LAKEFRONT CT NE	LAKE PLACID, FL 33852
MAURICE MARLENE TRUST		6350 SW 58TH CT	DAVIE, FL 33314
MCCORMICK CHARLES R		3367 N MCCORMICK RD	VINCENNES, IN 47591
MCKINNEY JOHN W + JANET L		1370 SEABAY RD	WESTON, FL 33326
MCLEAN BILLY J		PO BOX 11	CLARKSVILLE, FL 32430
MILLER ROBERT H + CORI L		5 SPUR RD	EDINA, MN 55436
MITCHELL VELMA F ET AL +	WEAVER EDWARD	107 ORANGE RD NE	LAKE PLACID, FL 33852
MORLEY CHRISTOPHER B + PURITERE		6741 NW 6 CT	MARGATE, FL 33063
MUIR ROBERT A + MARY ANN G +	KOCH MICHAEL J + CHRISTINE A	7100 POINT OF ROCKS CIR	SARASOTA, FL 34242
NELSON PAMELA A +	PATTERSON LINDA C	267 CALOOSA ESTATES DR	LABELLE, FL 33935
NICHOL LORNA L		118 ORANGE RD NE	LAKE PLACID, FL 33852
OLIVA SERGIO + MARIELA		111 LAKEFRONT CT NE	LAKE PLACID, FL 33852
ONEAL JAMES E + SAUNDRA J		641 E FREEPORT RD	MORRISTOWN, IN 46161
PATRICK GARY D JR TRUST		1530 NW 79 TER	PEMBROKE PINES, FL 33024
PFLUM MARK + JANET TRUST		108 ORANGE RD NE	LAKE PLACID, FL 33852
PLACID LAKES SPEC BENEFIT DIST	C/O BOARD OF CO COMMISSIONERS	PO BOX 1926	SEBRING, FL 33871
RATAJSKI THEODORE H		133 ORANGE RD NE	LAKE PLACID, FL 33852
REDDING NANCY LYNN		114 LAKEFRONT T NE	LAKE PLACID, FL 33852
REVELS GREGORY A + DEBORAH F		970 GULF WINDS WAY	NOKOMIS, FL 34275
RIDGELY JAMES ROBERT III TRUST +	RIDGELY ATHRIENNA MARLYN TRUST	880 SE 2ND AV	DANIA BEACH, FL 33004
ROBERTS JAMES + JACQUELYN		122 ORANGE RD NE	LAKE PLACID, FL 33852
RODDENBERRY MICHELE		371 CATFISH CREEK RD	LAKE PLACID, FL 33852
RYNAR MARC DAVID		512 CATFISH CREEK RD	LAKE PLACID, FL 33852
SALEEBA A J + TONYA L TRUSTEES		113 ORANGE RD NE	LAKE PLACID, FL 33852
SANSONE DAVID R + PATTI		17181 GULF PINE CIRCLE	WELLINGTON, FL 33414
SAUVE GERALD M + RAMA JEAN TRUST	C/O JAMES BROWNING TRUSTEE	401 CATFISH CREEK RD	LAKE PLACID, FL 33852
SCOPA RICHARD J + DEBORAH L		2041 NW 85TH AV	PEMBROKE PINES, FL 33024
SHEHORN SHANE B + HEATHER A		116 ORANGE RD NE	LAKE PLACID, FL 33852
SUTER F J JR + BETTY ANN TRS		119 ORANGE RD NE	LAKE PLACID, FL 33852
SWENSON BENJAMIN R + LISA F		406 CATFISH CREEK RD	LAKE PLACID, FL 33852
TAYLOR JASON H + GRETCHEN G		15030 E FALCONS LEA DR	DAVIE, FL 33331
TEAM NADLAN SHUKI FL LLC		7520 NW 5TH ST #103	PLANTATION, FL 33317
THORN DANIEL R		114 ORANGE RD NE	LAKE PLACID, FL 33852
VANCE CHARLES E +	WALL JANICE G CO-TRUSTEES	111 ORANGE RD NE	LAKE PLACID, FL 33852
VOLKERS SCOTT PAUL +	VOLKERS JANE MARIE CO-TRUSTEES	524 CATFISH CREEK RD	LAKE PLACID, FL 33852
VOLTZ DONALD M + EFFIE		536 CATFISH CREEK RD	LAKE PLACID, FL 33852
WALDER JOHN + MICHELLE D		30058 BAYVIEW DR	GIBRALTAR, MI 48173
WARD WALLACE W JR + DORIS J		110 LAKEFRONT CT NE	LAKE PLACID, FL 33852
WARREN JACKIE + LYDA L		528 CATFISH CREEK RD	LAKE PLACID, FL 33852

NAME 1	NAME 2	ADDRESS 1	ADDRESS 2
WHIDDON GENE A JR + CATHERINE C		1627 SE 9 ST	FT LAUDERDALE, FL 33316
WISNOM WADE + CHRISTINE		3730 CHESTNUT RD	BALTIMORE, MD 21220
XTREME SYSTEMS INC		11220 INGLEWOOD DR	GIBSONTON, FL 33534
YENOR JEANNETTE TRUST		4859 NW 124TH WAY	CORAL SPRINGS, FL 33076
YERO JUSTIN LEE + CHRISTY RENEE		400 CATFISH CREEK RD	LAKE PLACID, FL 33852
YON PAUL DENNIS + ANN M BOWERS		13697 CUCKLE CREEK RD	BOWLING GREEN, OH 43402
ZACKE LARRY A + CASSANDRA M		8220 SW 96TH ST	MIAMI, FL 33156



# Catfish Creek Road Bridge Rehabilitation

Along Catfish Creek Road over Catfish Creek

January 2024

FPID Number: 446394-1-54-01  
HC Project Number: 22061

## PUBLIC WORKSHOP

Highlands County invites you to attend a Public Workshop on February 20, 2024 for the Catfish Creek Road Bridge Rehabilitation project.

This Public Workshop is being conducted to involve the public, local officials, and interested agencies in the project development process and to inform interested parties of the project's current status.

### LIVE IN-PERSON WORKSHOP:

Tuesday, February 20, 2024  
6:30 p.m. - 8 p.m. Open House

Placid Lakes Home & Property Owners  
Association Clubhouse  
2010 Placid Lakes Blvd  
Lake Placid, FL 33852



Catfish Creek Road bridge looking east.

## Project Overview

The existing bridge over Catfish Creek (shown in the photo) has two narrow travel lanes without shoulders or sidewalks. This project will seek to rehabilitate the existing bridge as well as identify ways to:

- Enhance safety
- Accommodate pedestrians and cyclists
- Meet future travel demand



## Catfish Creek Road Bridge Rehabilitation

Richard "OJ" Oujevolk  
Highlands County Engineering  
505 South Commerce Ave  
Sebring, FL 33870

Highlands County encourages the public to participate in the Catfish Creek Road Bridge Rehabilitation Public Workshop. If you have questions regarding the meeting, please contact the Highlands County Project Manager, Richard "OJ" Oujevolk, at:

Email: [ROujevolk@HighlandsFL.gov](mailto:ROujevolk@HighlandsFL.gov)

Highlands County Engineering  
505 South Commerce Ave  
Sebring, FL 33870

Contact Us

Public participation is solicited without regard to race, color, national origin, age, sex, religion, disability or family status. Persons who require special accommodations under the Americans with Disabilities Act should contact Sherri Bennett, Highlands County ADA Coordinator, by phone at (863) 402-6509 or by email at [HRManager@HighlandsFL.gov](mailto:HRManager@HighlandsFL.gov) at least five (5) days prior to the meeting. Persons who require translation services (free of charge) should contact Emmanuelle Rodriguez at (386) 271-0273 or email at [emmanuelle.rodriguez@kimley-horn.com](mailto:emmanuelle.rodriguez@kimley-horn.com) at least five (5) days prior to the meeting.

**OBITUARIES**

**Nancy A. Bain**



Nancy Ann Bain – beloved mother, grandmother, and cherished member of the community – peacefully departed this world while napping on her couch on Feb. 7, 2024, at the age of 86. Born Oct. 12, 1937, in Hebron, Ohio, Nancy's life was marked by love, laughter, and a passion for dance.

Preceded in death by her parents, Clarence H. Williams and Clara Louise Williams; husbands Ron Wilson and Thomas Bain; as well as her fiancé, Carl Pangle, Nancy leaves behind a legacy of resilience and joy.

She is survived by her adoring children, Ted Bain (Pam) of Braselton, Georgia, Snow Kendall (Greg) of Kennesaw, Georgia, and Tammera Jordan (Todd) of Flowery Branch, Georgia, as well as her cherished grandchildren, Sydney, Melody, Stuart, McKinzy, Sterling, Spencer, Kaitlyn, and Kimberly.

Nancy's life was a testament to her vibrant spirit and love for music and dance. Growing up in the big band era, she began dancing at the tender age of 12, swinging to the melodies of the big bands at Buckeye Lake. An avid dancer, she embraced various styles including ballroom, square, contra, and zydeco dancing.

Renowned as the Miss Majorette of Ohio, Nancy showcased her talent as a clarinet player in numerous bands, culminating in her participation with the Second Time Arounders marching band in Saint Petersburg. Her passion for music and marching was infectious, leaving a lasting impact on all her bandmates.

In her professional life, Nancy blazed trails as a project manager, pioneering the creation of the first computerized patient care systems in Ohio, Georgia and California. Her dedication and expertise led her to work onsite at over 50 mental health hospitals, improving the quality of care for countless people.

In her later career, she lent her skills as a project manager consultant for large consulting companies, leaving an indelible mark on projects both nationally and internationally.

Upon retirement, Nancy devoted herself to caring for her husband and mother, settling in Sebring, Florida where she established herself as a real estate professional, building the award-winning Gracious Homes from the ground up.

Nancy will be deeply missed by her family, friends, dance community, and all who had the privilege of knowing her. Her sense of style, kindness and love will be remembered fondly, forever etched in the hearts of those she leaves behind.

A visitation was held at Morris Funeral Chapel in Sebring, Florida from 12-2 p.m. Monday, Feb. 12. May her soul rest in eternal peace, and may her memory be a blessing to us all.

Arrangements by Morris Funeral Chapel, Sebring. www.morrisfuneralchapel.com.

**Heartland American Israeli Initiative speaker talks Israel**

BY TOM MEISENHEIMER  
Correspondent

The Heartland American Israeli Initiative began in 2015. The 501 c 3 Initiative was started by local Christian and Jewish residents of Highlands County. They established this mission statement:

"To support and promote vigorously the long-standing partnership between the United States and Israel by heightening awareness at the grass roots level among government representatives, local institutions and the general public."

HAII has made this

mission come alive by leading trips to Holocaust museums and memorials in Florida as well as holding monthly luncheon meetings during the winter season. Speakers have included Israeli military vets, family members of Holocaust survivors, Jewish Rabbis, Christian clergy and many other Israeli experts.

The luncheon meetings are held at Inn on the Lakes at 3101 Golfview Drive in Sebring. The meetings are open to the public and begin at 11:45 with lunch on your own from the special menu.

The next luncheon

meeting will be held Wednesday, Feb. 14. HAII member Millie Anderson will be the guest speaker. Anderson spoke on the topic "How well do you know Israel?" last April. Based on the current war in Israel, she will return to continue an informative Part Two discussion based upon current events in the only democracy in the Middle East.

Attendance to any HAII luncheon is open and encouraged for the public to attend. HAII President Bobby Lee said, "To assure that HAII continues to bring compelling speakers to

Highlands County you can become a member for \$25 (individual) and \$50 (family)."

Simply send a check for membership or other gift made out to HAII. Send it to Initiative Treasurer Linda Kolarik at 1113 Lakeside Way, Sebring, FL 33876. Your membership or other gift is tax deductible and allows HAII to continually present guests to update the community about the tremendous contributions Israel has and continues to make to the world in the fields of agriculture, science and medicine.

**FEARS**  
FROM PAGE 1A

all," Scholz said without mentioning the former president by name. "And let me say clearly for current reasons: Any relativization of NATO's support guarantee is irresponsible and dangerous, and is in the interest of Russia alone."

"No one can play, or 'deal,' with Europe's security," the chancellor added.

Earlier Monday, Scholz inaugurated a new ammunition factory, underlining Europe's efforts to ramp up weapons production.

Tusk also urged European nations to invest more in military projects in order "to achieve

as quickly as possible... in the next dozen or so months, much greater air defense capabilities, much greater production capabilities in terms of ammunition."

Asked about Trump's remarks, Tusk said they "should act like a cold shower for all those who continue to underestimate this increasingly real threat which Europe is facing."

Macron, speaking alongside Tusk in Paris, said Europe's will "to further supply and meet Ukrainian needs is crucial," after leaders of the 27 EU member nations sealed a deal to provide Ukraine with 50 billion euros (\$54 billion) in support for its war-ravaged economy.

This "will enable us

to make from Europe a security and defense power that is both complementary to NATO and a pillar of the Atlantic alliance, Macron said.

Trump's remarks raised concerns that if reelected, he could embolden Russia to attack other countries besides Ukraine. NATO Secretary-General Jens Stoltenberg issued a statement Sunday saying that Trump's remarks put American troops and their allies at greater risk.

NATO does not require its 31 members to pay bills, but they are expected to invest a certain percentage of their own budgets — ideally, 2% of their gross domestic product — on defense.

Some countries, like Poland, have long met the target. Other European nations ramped up their military spending after Russia invaded Ukraine almost two years ago.

Germany, with a post-World War II political culture of military caution, was a frequent target of Trump's ire during his presidency for falling short of the 2% target. But Berlin announced plans to step up military spending after the full-scale invasion of Ukraine and plans to hit the benchmark this year.

France's military budget grew in recent years and reached the level of about 2% of GDP.

Moulson contributed from Berlin and Gera from Warsaw.

**LOADS**  
FROM PAGE 1A

County Sheriff's deputies to patrol the road to catch anyone with unsecured loads.

"You can't fix stupid," Kirouac said. "People are irre-

sponsible. Unless you catch somebody in the act, it's very difficult to prosecute them."

The Sheriff's Office is aware of the issue on Arbuckle Creek Road.

Sheriff Paul Blackman filmed a public service video warning drivers to cover

their loads. He poses next to a road sign on Arbuckle Creek Road that reads: "State Law: Loads Must Be Properly Covered. \$500 fine."

He holds up a handful of rusted screws and nails to the camera.

"This is only a few minutes

of walking down Arbuckle Creek Road," he says. "Our deputies will continue to enforce the unsecured load (law) as people go to the landfill."

Metal, wood, as well as paper and plastic from unsecured loads not only litter

the landscape, they can also endanger cattle and other livestock. When the plastic snags on pasture fences or blows into fields, cattle can eat the plastic and choke to death, Arbuckle Creek rancher Justin Hartt says in the video.

**COMPOST**  
FROM PAGE 1A

to the Special Exception approval.

Tuesday's agenda packet has been updated to reflect the reversal of opinion. The Highlands News-Sun was furnished a copy of the agenda item Friday evening.

The "combination" of exceptions on the agenda is "crushing, screening and processing of materials excavated on premises; Commercial activity directly serving agricultural pursuits and limited to the service of agricultural pursuits; and store, recycle, or mulch, soil, sand, muck and natural vegetative material – to allow an expansion of an existing compost



KIM MOODY/STAFF

Compost USA is seeking a special exception from the county that would allow its expansion to 160 acres.

operation."

In the revised agenda, the staff noted that the site visit was prompted by complaints that came in around Jan. 29 from nearby property owners. The neighbors cited "offensive odors and buzzards" at the current site. The site visit revealed exactly that – "a large number of

environmental Protection (FDEP)."

The staff findings include:

- The odors coming from the plant affect the public interest and would increase if the plant expands.

- "The odor and buzzards at the existing operation have, more probable than not, injured the value of adjoining or abutting property. Expanding such a use would, more probable than not, further injure the value of adjoining or abutting property."

- The expansion of Compost USA would not be in "harmony" with neighboring properties.

- "If the requested expansion were to be approved and be conducted in the same manner as the existing operation, it would not

comply with the Highlands County Code of Ordinances (Code) specifically related to Chapter 5.6, Nuisances. The existing operation was reported to Highlands County Code Enforcement on February 8, 2024."

Whether the expansion is a good thing or not depends on who you ask and where they live in proximity to Compost USA. Many neighbors will be relieved if the Board of Adjusters accepts the county's opinion and denies the exception.

Several letters from neighbors came in opposing the expansion citing the inability to open their windows or use their property as they would like because of the smell.

Even property owners such as Butch Thompson said he is not against the product produced by the company and has even used it himself. However, as the company stands now, he said the smell and the buzzards are a nuisance.

On the other hand, a number of citrus growers who use the product wrote letters in support of the expansion. In (mostly) a form letter, the growers said the product is beneficial to their industry and the expansion would "assure the future supply."

County Commissioner Arlene Tuck said anyone with interests in this matter needs to be at the meeting Tuesday and have their opinions heard.

**County of Highlands**  
When: February 20, 2024, 6:30 p.m. - 8 p.m. open house  
Where: Placid Lakes Home & Property Owners Association Clubhouse  
Financial Project Identification (FPID) Numbers: 446394-1-54-01  
Highlands County Project Number: 22061  
Highlands County Project Contact: Richard "OJ" Oujevolk ROujevolk@HighlandsFL.gov

**Catfish Creek Road Bridge Rehabilitation**  
Highlands County invites you to a Public Workshop for the Catfish Creek Road Bridge Rehabilitation project (FPID number 446394-1-54-01 & HC Project number 22061) along Catfish Creek Road over Catfish Creek. The Public Workshop is being conducted to involve the public, local officials, and interested agencies in the project development process and to inform interested parties of the project's current status.  
**IN-PERSON WORKSHOP:**  
Tuesday, February 20, 2024  
6:30 p.m. - 8 p.m. open house  
Placid Lakes Home & Property Owners Association Clubhouse  
2010 Placid Lakes Blvd  
Lake Placid, FL 33852  
If you are unable to attend the meeting, comments can be provided by email (ROujevolk@HighlandsFL.gov) or mail (Highlands County Engineering, Attn: Richard "OJ" Oujevolk, 505 South Commerce Ave, Sebring, FL 33870). While comments about the project are accepted at any time, they must be received or postmarked by March 1, 2024, to be included in the formal workshop record. Questions can be answered by emailing the Highlands County project manager at ROujevolk@HighlandsFL.gov.  
Highlands County is sending notices to property owners, business owners, interested persons and organizations within 300 feet of the project to provide the opportunity to give comments to Highlands County regarding this project. Public participation is solicited without regard to race, color, national origin, age, sex, religion, disability or family status. Persons who require special accommodations under the Americans with Disabilities Act should contact Sherri Bennett, Highlands County ADA Coordinator, by phone at (863) 402-6509 or by email at HRManager@HighlandsFL.gov at least five (5) days prior to the meeting. Persons who require translation services (free of charge) should contact Emanuelle Rodriguez at (386) 271-0273 or email at emanuelle.rodriguez@kimley-horn.com at least five (5) days prior to the meeting.

## **APPENDIX B**

### Public Workshop Materials



# CATFISH CREEK ROAD BRIDGE REHABILITATION

Along Catfish Creek Road over Catfish Creek

Public Workshop | February 20, 2024

FPID No. 446394-1-54-01 & HC Project No. 22061

## PLEASE SIGN IN

Name	Email
1 Jim HEPBURN	JHEPBURN@LIVE.COM
2 MIKE BROOKIN'S	
3 WARREN WALKER	
4 Toni + Darl Collins	toni.collins@etczone.com
5 Ron Walther	lch414@outlook.com
6 Linda C. Halbach	lch 414 @ outlook.com
7 JOHN BISCANIN	jpbiscanin17@gmail.com
8 Pam + Ron Ellerman	prellerman@gmail.com
9 John + Connie Luke	caluke1056@gmail.com
10 F. Beasler	
11 JOHN ARNESEN	JFARNESSEN@ME.COM
12 Marc Williams	bigred_836@yahoo.com
13 SUSAN + Charles Peabody	speabunny@gmail.com
14 Lisa Frantz	Lisa-frantz@ymail.com
15 Marcia Price	m1price@bellsouth.net
16 John Purcell	jpur2000@gmail.com
17 Jennifer + Mathias Hutzenlaub	hutze2000@aol.com
18 LARRY LANDRESS	larrylandress@gmail.com
19 Paul Yon	pyon@bgsu.edu
20 John Guerra	john.guerra@gmail.com

Note: All information provided on this sign-in sheet becomes public record and is subject to public records requests.



# CATFISH CREEK ROAD BRIDGE REHABILITATION

Along Catfish Creek Road over Catfish Creek

Public Workshop | February 20, 2024

FPID No. 446394-1-54-01 & HC Project No. 22061

## PLEASE SIGN IN

Name	Email
1 Al Tonioni	donnatonioni@gmail.com
2 ROGER POIRIER	POIRIERROG@AOL.COM
3 Edie Voltz	dolv4654@gmail.com
4 Guy Engelbert	guyengelbert@centurylink.net
5 JOANNE DOMBROWSKI	chemo_angel@yahoo.com
6 James Penland	Jimpenland1013@yahoo.com
7 Richard T Jelic	54itkgawr@ptb.net
8 KEVIN MCCARTHY	KMCCARTHY1011@ICLOUD.COM
9 JANICE WALL Book 6	JCTWALL@YAHOO.COM
10	
11 SCOT HOVERMAN	Shoverman@MSN.COM
12 Brad Shuman	Bshuman141@comcast.net
13 Dennis Henderson	dennishenderson2@Comcast.net
14 William Ringer	TomDADRinger@G-MAIL.COM
15 Carol Womacks	CarolWomacks@yahoo.com
16 Chris Truzinsky	Ctruzinsky@highlandsfl.gov
17 Terri Giroux / Wade Gerrard	
18 kept low	
19 Bill Thering	BThering1952@gmail.com
20 GENE HARGRAVE	genehargrave@yahoo.com

Note: All information provided on this sign-in sheet becomes public record and is subject to public records requests.





# CATFISH CREEK ROAD BRIDGE REHABILITATION

Along Catfish Creek Road over Catfish Creek

Public Workshop | February 20, 2024

FPID No. 446394-1-54-01 & HC Project No. 22061

## PLEASE SIGN IN

	Name	Email
1	Pedro Varona	BP CHARTERS @ YAHOO.OO
2	Stephanie Asher	agdstephanie@me.com
3	Anne Sly	annemsly@yahoo.com
4		
5		
6		
7		
8		
9		
10		
11		
12		
13		
14		
15		
16		
17		
18		
19		
20		

Note: All information provided on this sign-in sheet becomes public record and is subject to public records requests.



# CATFISH CREEK ROAD BRIDGE REHABILITATION

Along Catfish Creek Road over Catfish Creek

Public Workshop | February 20, 2024

FPID No. 446394-1-54-01 & HC Project No. 22061

## ~~ELECTED OFFICIALS SIGN IN SHEET~~

NAME

EMAIL

~~NAME~~

INITIALS

Didgie Trono

argodidgie@gmail.com -

DV. X

Bob Belscher

CRBelsch@gmail.com

CRB. X

Note: All information provided on this sign-in sheet becomes public record and is subject to public records requests.



# CATFISH CREEK ROAD BRIDGE REHABILITATION

Along Catfish Creek Road over Catfish Creek

FPID No. 446394-1-54-01 & HC Project No. 22061

Public Workshop | February 20, 2024

## STAFF SIGN IN SHEET

NAME	AGENCY	EMAIL	INITIALS
Richard Oujevolk	Highlands County	roujevolk@highlandsfl.gov	✓
James Langford	Highlands County	jdlangford@highlandsfl.gov	
Joseph DeFronzo	Highlands County	jdefronzo@highlandsfl.gov	
Clinton Howerton	Highlands County	chowerton@highlandsfl.gov	
Kenya Anderson	Highlands County	kanderson@highlandsfl.gov	
Karen Clogston	Highlands County	kclogston@highlandsfl.gov	
Vickey Linsinbigler	Highlands County	vlinsinbigler@highlandsfl.gov	
Cheryl Gelinias	Highlands County	cgelinas@highlandsfl.gov	
Jennifer Willis	Highlands County	jwillis@highlandsfl.gov	
Cris Schooley	Kimley-Horn	cris.schooley@kimley-horn.com	CS
Josh Davis	Kimley-Horn	josh.davis@kimley-horn.com	JD
Amanda Black	Kimley-Horn	amanda.black@kimley-horn.com	AB
Shayna Eaton	Kimley-Horn	shayna.eaton@kimley-horn.com	SE

Note: All information provided on this sign-in sheet becomes public record and is subject to public records requests.





# Catfish Creek Road Bridge Rehabilitation

Along Catfish Creek Road over Catfish Creek

January 2024

FPID Number: 446394-1-54-01  
 HC Project Number: 22061

## Project Overview

The existing bridge over Catfish Creek (shown in the photo) has two narrow travel lanes without shoulders or sidewalks. This project will seek to rehabilitate the existing bridge as well as identify ways to:

- Enhance safety
- Accommodate pedestrians and cyclists
- Meet future travel demand



Catfish Creek Road bridge looking east.



**Public Workshop:**  
 Placid Lakes Home &  
 Property Owners  
 Association Clubhouse

## Agenda

Today's public workshop:

1. Introduction to current project
2. Citizen input on potential interim solution
3. Citizen input on future bridge

Next steps:

4. Summarize public input and recommend future bridge project
5. Complete bridge repair plans

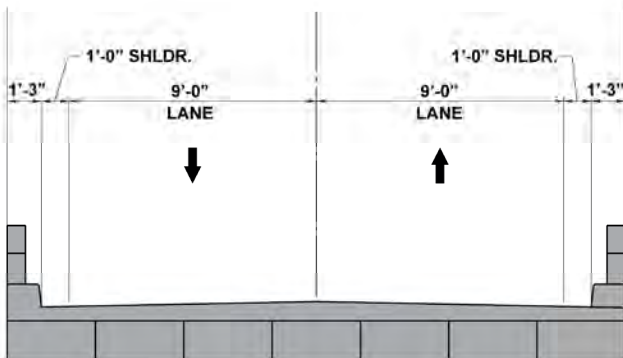

Existing typical section of Catfish Creek Road bridge.



# Catfish Creek Road Bridge Rehabilitation

Along Catfish Creek Road over Catfish Creek

## Provide Feedback

We want your ideas on how to improve Catfish Creek Road Bridge!

How to comment:

- Submit a comment form tonight
- Mail comment form to Richard Oujevolk, Highlands County Project Manager, by **March 1, 2024**
- Send e-mail to [ROujevolk@HighlandsFL.gov](mailto:ROujevolk@HighlandsFL.gov)

**Catfish Creek Road Bridge Rehabilitation**  
Along Catfish Creek Road over Catfish Creek  
 FPD No. 446394-J-34-01 & HC Project No. 22061

COMMENT FORM

PUBLIC WORKSHOP

Tuesday, February 20, 2024  
 Placid Lakes Home & Property Owners Association Clubhouse

Please provide your comments below. If more space is needed, please use the back of this sheet or an additional sheet of paper. You may place your comments in the "Comment Box" provided at the meeting or send them to Richard "DJ" Oujevolk at the address below. E-mailed comments are also accepted. Comments postmarked by Friday, March 1, 2024 will become part of the public meeting record.

Name

PUBLIC WORKSHOP  
 Richard "DJ" Oujevolk  
 Highlands County Engineering  
 100 South Commerce Drive  
 Sebring, FL 33870  
 Email: [ROujevolk@HighlandsFL.gov](mailto:ROujevolk@HighlandsFL.gov)

Address

City, State, Zip Code

Affiliation

Email Address

NOTE: The information you provide on this comment form becomes part of the study's project files. This information may be provided to other individuals who make a public comment request.

## Project Schedule





**CATFISH CREEK ROAD  
BRIDGE REHABILITATION**  
Along Catfish Creek Road over Catfish Creek

**Public Workshop**  
February 20, 2024

# **WELCOME TO THE PUBLIC WORKSHOP**

***Catfish Creek Road Bridge Rehabilitation***  
***Along Catfish Creek Road over Catfish Creek***

**Tuesday, February 20, 2024**



**CATFISH CREEK ROAD  
BRIDGE REHABILITATION**  
Along Catfish Creek Road over Catfish Creek

# TITLE VI

**Public Workshop**  
February 20, 2024

This project has been developed in compliance with Title VI of the Civil Rights Act of 1964 and other federal and state nondiscrimination authorities. Neither Highlands County nor this project will deny the benefits of, exclude from participation in, or subject to discrimination anyone on the basis of race, color, religion, national origin, age, sex, disability, or family status. Persons wishing to express their concerns relative to Highlands County compliance with Title VI may do so by contacting:

**Sherri Bennett**  
**ADA Compliance Coordinator**  
(863) 402-6509  
HRManager@HighlandsFL.gov

**Stefan Kulakowski**  
**State Title VI Coordinator**  
(850) 414-4742  
Stefan.Kulakowski@dot.state.fl.us

*All inquiries or complaints will be handled according to Highlands County procedures and in a prompt and courteous manner.*



**CATFISH CREEK ROAD  
BRIDGE REHABILITATION**  
Along Catfish Creek Road over Catfish Creek

# TRAFFIC

Public Workshop  
February 20, 2024

## 3-Day Average Vehicle Volume

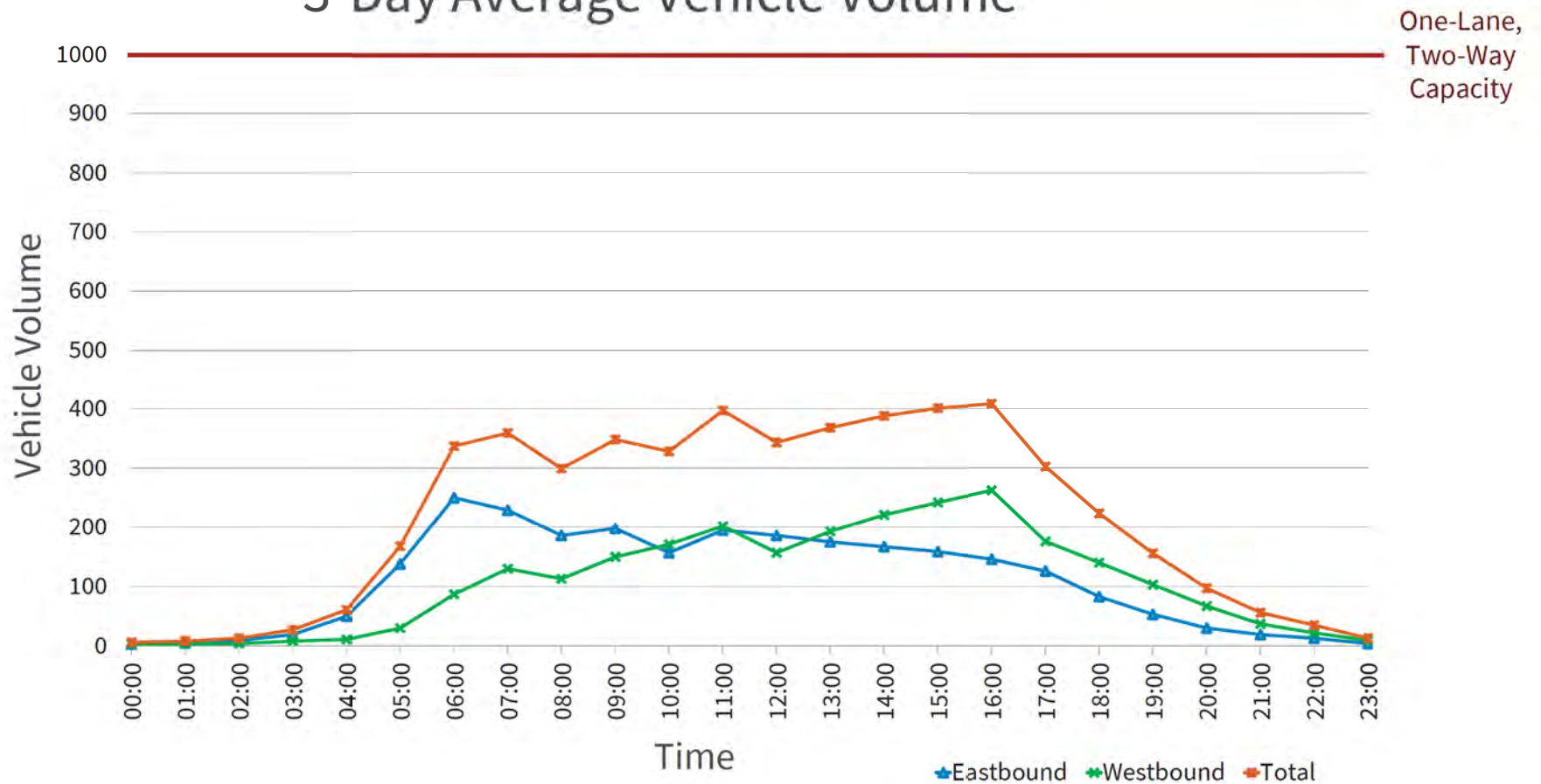



**CATFISH CREEK ROAD  
BRIDGE REHABILITATION**  
Along Catfish Creek Road over Catfish Creek

# PROJECT SCHEDULE

Public Workshop  
February 20, 2024



**WE ARE HERE**



**CATFISH CREEK ROAD  
BRIDGE REHABILITATION**  
Along Catfish Creek Road over Catfish Creek

# AGENDA

**Public Workshop**  
February 20, 2024

## **Today's public workshop:**

- 1** Introduction to current project
- 2** Citizen input on potential interim solution
- 3** Citizen input on future bridge

## **Next steps:**

- 4** Summarize public input and recommend future bridge project
- 5** Complete bridge repair plans





**CATFISH CREEK ROAD  
BRIDGE REHABILITATION**  
Along Catfish Creek Road over Catfish Creek

# EXISTING CONDITIONS

Public Workshop  
February 20, 2024





**CATFISH CREEK ROAD  
BRIDGE REHABILITATION**  
Along Catfish Creek Road over Catfish Creek

**Public Workshop**  
February 20, 2024

**THANK YOU FOR ATTENDING THE**  
***CATFISH CREEK ROAD BRIDGE***  
***REHABILITATION***  
**PUBLIC WORKSHOP**



# CATFISH CREEK ROAD BRIDGE REHABILITATION

Along Catfish Creek Road over Catfish Creek

Public Workshop  
February 20, 2024

# PROJECT LOCATION





# CATFISH CREEK ROAD BRIDGE REHABILITATION

Along Catfish Creek Road over Catfish Creek

Public Workshop  
February 20, 2024

# TYPICAL SECTIONS

## Existing Conditions

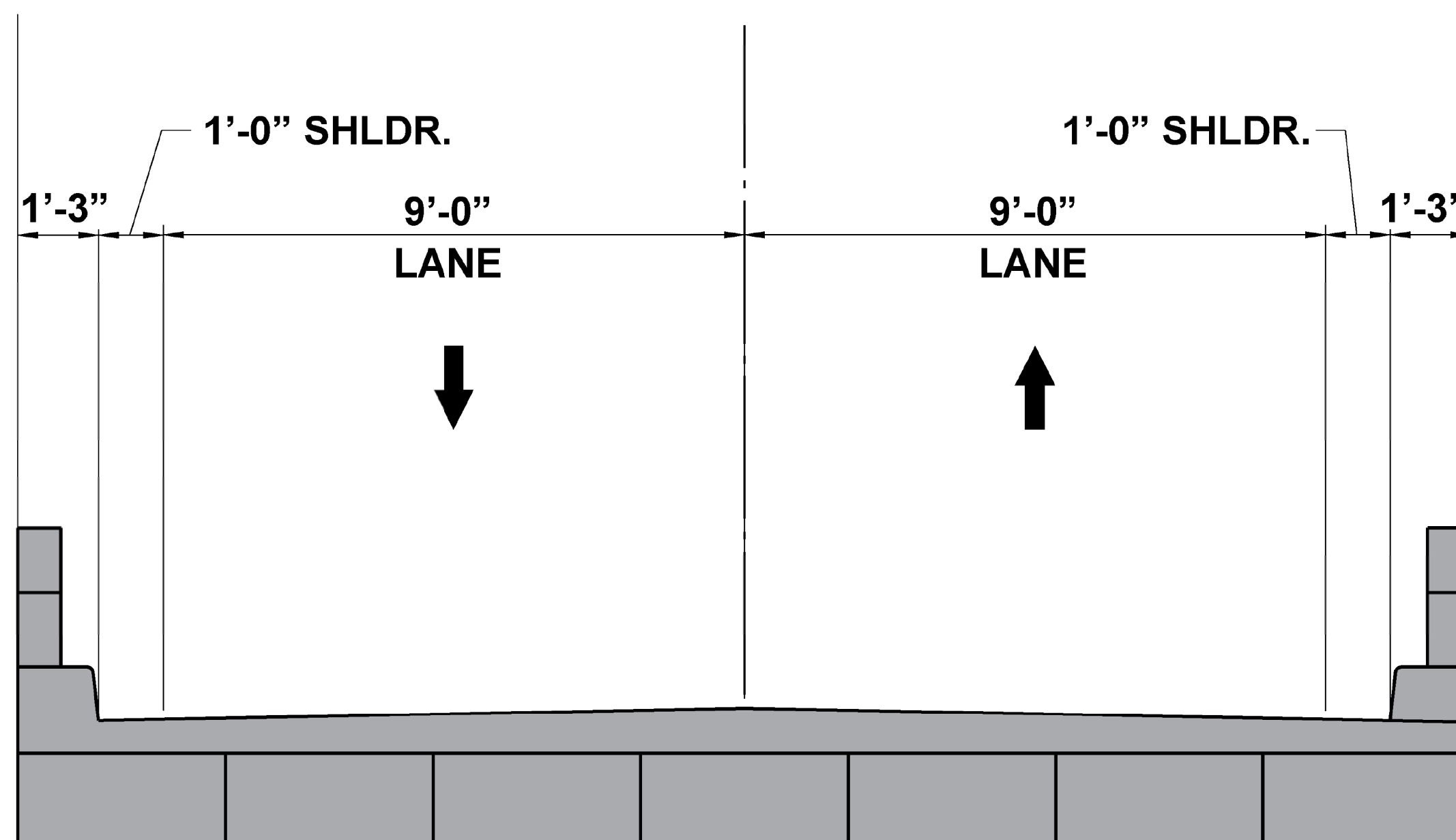

## Future Bridge Replacement (Unfunded)

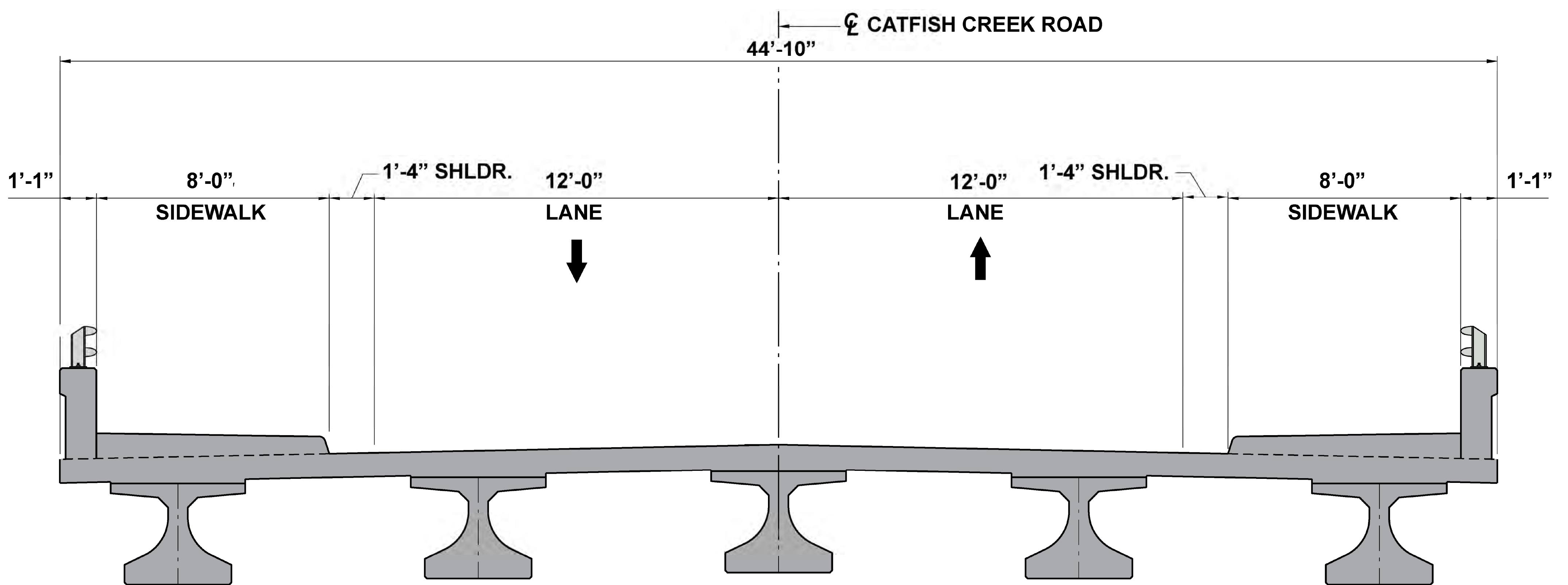



# TYPICAL SECTIONS

## Alternative 1 - Interim Bridge

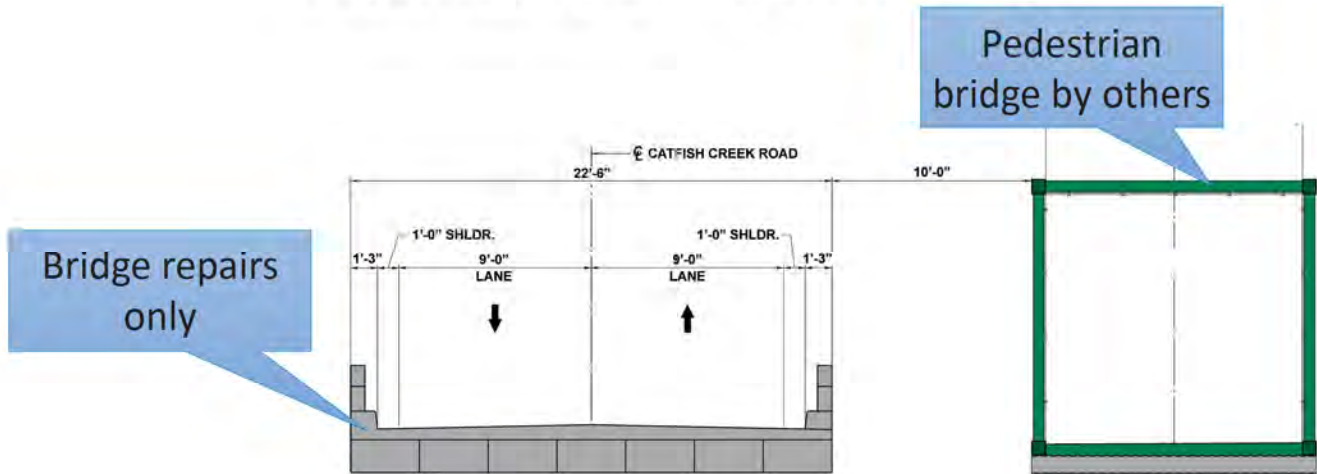

## Alternative 2 - Interim Bridge

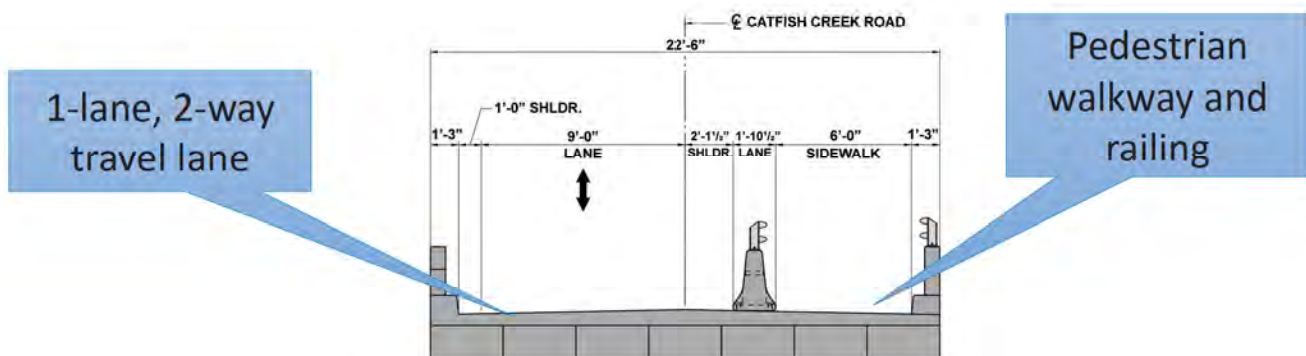



# CATFISH CREEK ROAD BRIDGE REHABILITATION

Along Catfish Creek Road over Catfish Creek

Public Workshop  
February 20, 2024

# TYPICAL SECTIONS

## Alternative 3 - Interim Bridge

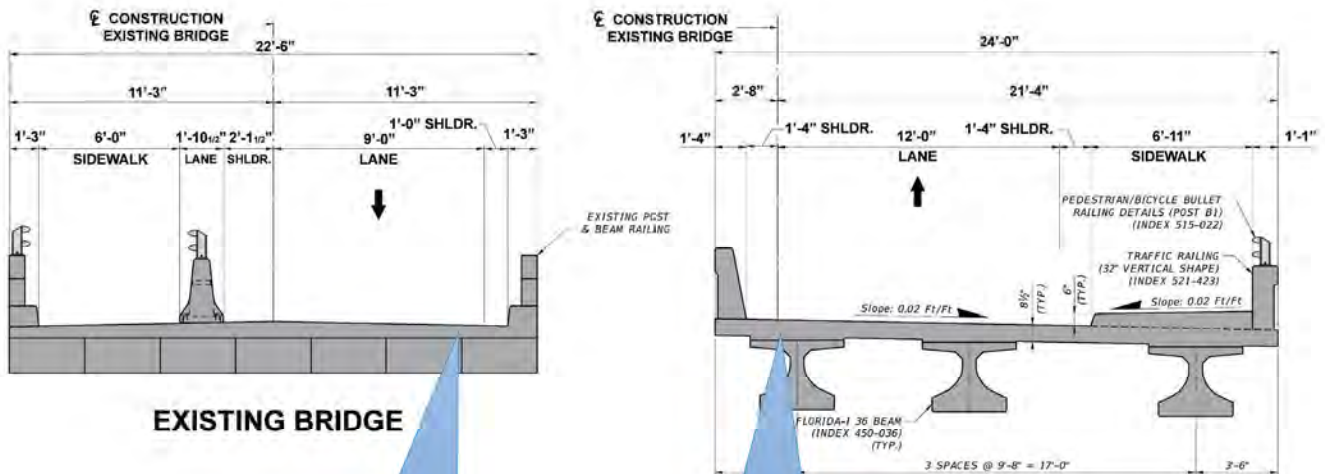

EXISTING BRIDGE

Retrofit bridge  
for Westbound  
only

New Eastbound  
bridge

## **APPENDIX C**

### Public Comments



# Catfish Creek Road Bridge Rehabilitation

Along Catfish Creek Road over Catfish Creek

FPID No. 446394-1-54-01 & HC Project No. 22061

## COMMENT FORM

### PUBLIC WORKSHOP

Tuesday, February 20, 2024

Placid Lakes Home & Property Owners Association Clubhouse

Please provide your comments below. If more space is needed, please use the back of this sheet or an additional sheet of paper. You may place your comments in the "Comment Box" provided at the meeting or send them to Richard "OJ" Oujevolk at the address below. E-mailed comments are also accepted. **Comments postmarked by Friday, March 1, 2024 will become part of the public meeting record.**

We need a new Bridge - not a repair on an old bridge. There are more cars ~~on~~ traveling on Catfish Creek Rd than ever before. Boats are larger than they were in 1961. Some can't get under the existing bridge so they sit on peoples property. ~~Rating~~ Why spend money to repair an obsolete bridge?

Name

Linda Halbach

Address

Lake Placid  
275 Cumquat Rd NE FL 33852  
City, State, Zip Code

Affiliation

Lch414@outlook.com

Email Address

#### PLEASE RETURN COMMENTS TO

Richard "OJ" Oujevolk  
Highlands County Engineering  
505 South Commerce Ave.  
Sebring, FL 33870  
Email: Roujevolk@HighlandsFL.gov

Comments must be postmarked by:  
Friday, March 1, 2024

NOTE: The information you provide on this comment form becomes part of the study's project files. This information may be provided to other individuals who make a public records request.



# Catfish Creek Road Bridge Rehabilitation

Along Catfish Creek Road over Catfish Creek

FPID No. 446394-1-54-01 & HC Project No. 22061

## COMMENT FORM

### PUBLIC WORKSHOP

Tuesday, February 20, 2024

Placid Lakes Home & Property Owners Association Clubhouse

Please provide your comments below. If more space is needed, please use the back of this sheet or an additional sheet of paper. You may place your comments in the "Comment Box" provided at the meeting or send them to Richard "OJ" Oujevolk at the address below. E-mailed comments are also accepted. **Comments postmarked by Friday, March 1, 2024 will become part of the public meeting record.**

Would love to see separate <sup>trail</sup> pedestrian bridge placed @ southern edge of right of way allowing room for widening/replacement bridge as funding is available. Alternative 1 - leverage ~~the~~ Polk/Collier Trail safer routes to schools

KEVIN McCARTHY

Name

120 Lime Rd NE

Address

Lake Placid, FL 33852

City, State, Zip Code

Affiliation

Kmccarthy1011@icloud.com

Email Address

#### PLEASE RETURN COMMENTS TO

Richard "OJ" Oujevolk  
Highlands County Engineering  
505 South Commerce Ave.  
Sebring, FL 33870

Email: Roujevolk@HighlandsFL.gov

Comments must be postmarked by:  
Friday, March 1, 2024

NOTE: The information you provide on this comment form becomes part of the study's project files. This information may be provided to other individuals who make a public records request.





# Catfish Creek Road Bridge Rehabilitation

Along Catfish Creek Road over Catfish Creek

FPID No. 446394-1-54-01 & HC Project No. 22061

## COMMENT FORM

### PUBLIC WORKSHOP

Tuesday, February 20, 2024

Placid Lakes Home & Property Owners Association Clubhouse

Please provide your comments below. If more space is needed, please use the back of this sheet or an additional sheet of paper. You may place your comments in the "Comment Box" provided at the meeting or send them to Richard "OJ" Oujevolk at the address below. E-mailed comments are also accepted. **Comments postmarked by Friday, March 1, 2024 will become part of the public meeting record.**

① Because of the financial limitations currently existing - add to the existing budget a walkway / bike way that has sufficient guard rails for safety.

② Reduce speed further back east and west with occasional police attendance to regulate - ~~prevent~~ punish speeders.

JOHN BISCANNI

Name

Address

City, State, Zip Code

Affiliation

Email Address

#### PLEASE RETURN COMMENTS TO

Richard "OJ" Oujevolk  
Highlands County Engineering  
505 South Commerce Ave.  
Sebring, FL 33870  
Email: Roujevolk@HighlandsFL.gov

Comments must be postmarked by:  
Friday, March 1, 2024

NOTE: The information you provide on this comment form becomes part of the study's project files. This information may be provided to other individuals who make a public records request.



# Catfish Creek Road Bridge Rehabilitation

Along Catfish Creek Road over Catfish Creek

FPID No. 446394-1-54-01 & HC Project No. 22061

## COMMENT FORM

### PUBLIC WORKSHOP

Tuesday, February 20, 2024

Placid Lakes Home & Property Owners Association Clubhouse

Please provide your comments below. If more space is needed, please use the back of this sheet or an additional sheet of paper. You may place your comments in the "Comment Box" provided at the meeting or send them to Richard "OJ" Oujevolk at the address below. E-mailed comments are also accepted. **Comments postmarked by Friday, March 1, 2024 will become part of the public meeting record.**

- ① Recommendation for april 2024 - Put another, <sup>blinking</sup> lighted sign that says - 35mph - SLOW!
- ② Do a study of reported accidents per year (separate winter + summer)
- ③ Figure a way to get cars + trucks to go over at different times so to avoid opposite side hitting
- ④ Alternative 3 - Looks good! (mirrors hitting)
- ⑤ Lost Lake Bridge - an alternative?

Name SUSAN + Charles Peabody

Address 246 Cumquat Rd NE

City, State, Zip Code Lake Placid, FL, 33852

Affiliation Home owner

Email Address speabunny@gmail.com

#### PLEASE RETURN COMMENTS TO

Richard "OJ" Oujevolk  
 Highlands County Engineering  
 505 South Commerce Ave.  
 Sebring, FL 33870  
 Email: Roujevolk@HighlandsFL.gov

Comments must be postmarked by:  
 Friday, March 1, 2024

NOTE: The information you provide on this comment form becomes part of the study's project files. This information may be provided to other individuals who make a public records request.



# Catfish Creek Road Bridge Rehabilitation

Along Catfish Creek Road over Catfish Creek

FPID No. 446394-1-54-01 & HC Project No. 22061

## COMMENT FORM

### PUBLIC WORKSHOP

Tuesday, February 20, 2024

Placid Lakes Home & Property Owners Association Clubhouse

Please provide your comments below. If more space is needed, please use the back of this sheet or an additional sheet of paper. You may place your comments in the "Comment Box" provided at the meeting or send them to Richard "OJ" Oujevolk at the address below. E-mailed comments are also accepted. **Comments postmarked by Friday, March 1, 2024 will become part of the public meeting record.**

WHAT WE LEARNED IS THAT SHORT TERM (2yrs 9mos) ONLY MAINTENANCE WILL BE DONE @ A COST OF \$390K.

WHAT WE WANT IS IMPROVEMENTS IN DESIGN TO A DANGEROUS BRIDGE: TOO NARROW FOR 2 LANE CARS; TOO LOW FOR BOATS UNDERNEATH, NO SAFE WAY TO WALK OR BIKE ACROSS WITH CAR TRAFFIC.

SO GOAL SHOULD BE GETTING \$ & PRIORITIZED FOR THE NEW DESIGN

FRAN BEARDEN  
Name

157 CITRUS RD NE  
Address

LAKE PLACID FL 33852  
City, State, Zip Code

Affiliation

Email Address

#### PLEASE RETURN COMMENTS TO

Richard "OJ" Oujevolk  
Highlands County Engineering  
505 South Commerce Ave.  
Sebring, FL 33870  
Email: Roujevolk@HighlandsFL.gov

Comments must be postmarked by:  
Friday, March 1, 2024

NOTE: The information you provide on this comment form becomes part of the study's project files. This information may be provided to other individuals who make a public records request.



# Catfish Creek Road Bridge Rehabilitation

Along Catfish Creek Road over Catfish Creek

FPID No. 446394-1-54-01 & HC Project No. 22061

## COMMENT FORM

### PUBLIC WORKSHOP

Tuesday, February 20, 2024

Placid Lakes Home & Property Owners Association Clubhouse

Please provide your comments below. If more space is needed, please use the back of this sheet or an additional sheet of paper. You may place your comments in the "Comment Box" provided at the meeting or send them to Richard "OJ" Oujevolk at the address below. E-mailed comments are also accepted. **Comments postmarked by Friday, March 1, 2024 will become part of the public meeting record.**

Consider adding a traffic calming zone. A type of median in Catfish Creek about an eighth (1/8) mile before bridge.

Mare Williams

Name

111 Lime Rd NW

Address

Lake Placid FL 33852

City, State, Zip Code

Affiliation

bigred\_836@yahoo.com

Email Address

#### PLEASE RETURN COMMENTS TO

Richard "OJ" Oujevolk  
Highlands County Engineering  
505 South Commerce Ave.  
Sebring, FL 33870

Email: Roujevolk@HighlandsFL.gov

Comments must be postmarked by:  
Friday, March 1, 2024

NOTE: The information you provide on this comment form becomes part of the study's project files. This information may be provided to other individuals who make a public records request.



# Catfish Creek Road Bridge Rehabilitation

Along Catfish Creek Road over Catfish Creek

FPID No. 446394-1-54-01 & HC Project No. 22061

## COMMENT FORM

### PUBLIC WORKSHOP

Tuesday, February 20, 2024

Placid Lakes Home & Property Owners Association Clubhouse

Please provide your comments below. If more space is needed, please use the back of this sheet or an additional sheet of paper. You may place your comments in the "Comment Box" provided at the meeting or send them to Richard "OJ" Oujevolk at the address below. E-mailed comments are also accepted. **Comments postmarked by Friday, March 1, 2024 will become part of the public meeting record.**

Do nothing at this time

Bank the money until we can afford a new higher wider bridge

Name

Carol Womack

Address

140 Loquat Rd NE, LP, Fla

City, State, Zip Code

Realtor - Xtreme Realty

Affiliation

Carol.WOMACKS@yahoo.com

Email Address

#### PLEASE RETURN COMMENTS TO

Richard "OJ" Oujevolk  
Highlands County Engineering  
505 South Commerce Ave.  
Sebring, FL 33870  
Email: Roujevolk@HighlandsFL.gov

Comments must be postmarked by:  
Friday, March 1, 2024

NOTE: The information you provide on this comment form becomes part of the study's project files. This information may be provided to other individuals who make a public records request.



# Catfish Creek Road Bridge Rehabilitation

Along Catfish Creek Road over Catfish Creek

FPID No. 446394-1-54-01 & HC Project No. 22061

## COMMENT FORM

### PUBLIC WORKSHOP

Tuesday, February 20, 2024

Placid Lakes Home & Property Owners Association Clubhouse

Please provide your comments below. If more space is needed, please use the back of this sheet or an additional sheet of paper. You may place your comments in the "Comment Box" provided at the meeting or send them to Richard "OJ" Oujevolk at the address below. E-mailed comments are also accepted. **Comments postmarked by Friday, March 1, 2024 will become part of the public meeting record.**

Flap Sticks middle of bridge (To prevent crossover for head on traffic)

LARRY LANDRESS

Name

775 Lake August Drive

Address

Lake Placid, FL 33852

City, State, Zip Code

Affiliation

LarryLandress@gmail.com

Email Address

#### PLEASE RETURN COMMENTS TO

Richard "OJ" Oujevolk  
Highlands County Engineering  
505 South Commerce Ave.  
Sebring, FL 33870  
Email: Roujevolk@HighlandsFL.gov

Comments must be postmarked by:  
Friday, March 1, 2024

NOTE: The information you provide on this comment form becomes part of the study's project files. This information may be provided to other individuals who make a public records request.



# Catfish Creek Road Bridge Rehabilitation

Along Catfish Creek Road over Catfish Creek

FPID No. 446394-1-54-01 & HC Project No. 22061

## COMMENT FORM

### PUBLIC WORKSHOP

Tuesday, February 20, 2024

Placid Lakes Home & Property Owners Association Clubhouse

Please provide your comments below. If more space is needed, please use the back of this sheet or an additional sheet of paper. You may place your comments in the "Comment Box" provided at the meeting or send them to Richard "OJ" Oujevolk at the address below. E-mailed comments are also accepted. **Comments postmarked by Friday, March 1, 2024 will become part of the public meeting record.**

My suggestion - Save the grant money until you can WIDEN-AND make the Bridge HIGHER. ITS a waste of \$

Name

Lisa Frantz

Address

315 Catfish Creek Rd

City, State, Zip Code

Lake Placid 33852 ymail.com

Affiliation

Xtreme Realty LisaFrantz@ymail.com

Email Address

#### PLEASE RETURN COMMENTS TO

Richard "OJ" Oujevolk  
Highlands County Engineering  
505 South Commerce Ave.  
Sebring, FL 33870  
Email: Roujevolk@HighlandsFL.gov

Comments must be postmarked by:  
Friday, March 1, 2024

NOTE: The information you provide on this comment form becomes part of the study's project files. This information may be provided to other individuals who make a public records request.



103 Murray Ct NW  
Lake Placid, FL 33852-9747

Catfish  
Creek

PLACE STICKER AT TOP OF ENVELOPE TO THE RIGHT  
OF THE RETURN ADDRESS. FOLD AT DOTTED LINE

**CERTIFIED MAIL**

TAMPA FL 335

Retail



23 JAN 2024 PM 7



33870

9589 0710 5270 0592 9316 11

RDC 99

U.S. POSTAGE PAID  
FCM LETTER  
LAKE PLACID, FL 33852  
JAN 23, 2024

**\$5.08**

R2304M113422-15

Highlands County Engineering  
Catfish Creek Road Bridge Rehabilitation  
505 S. Commerce Ave.  
Sebring, Fl. 33870

ATTN: "OJ" OUJEVOLK

RECEIVED  
BOARD OF COUNTY COMMISSIONERS

JAN 25 2024

ENGINEERING DEPT  
HIGHLANDS COUNTY, FLORIDA

33870-386905



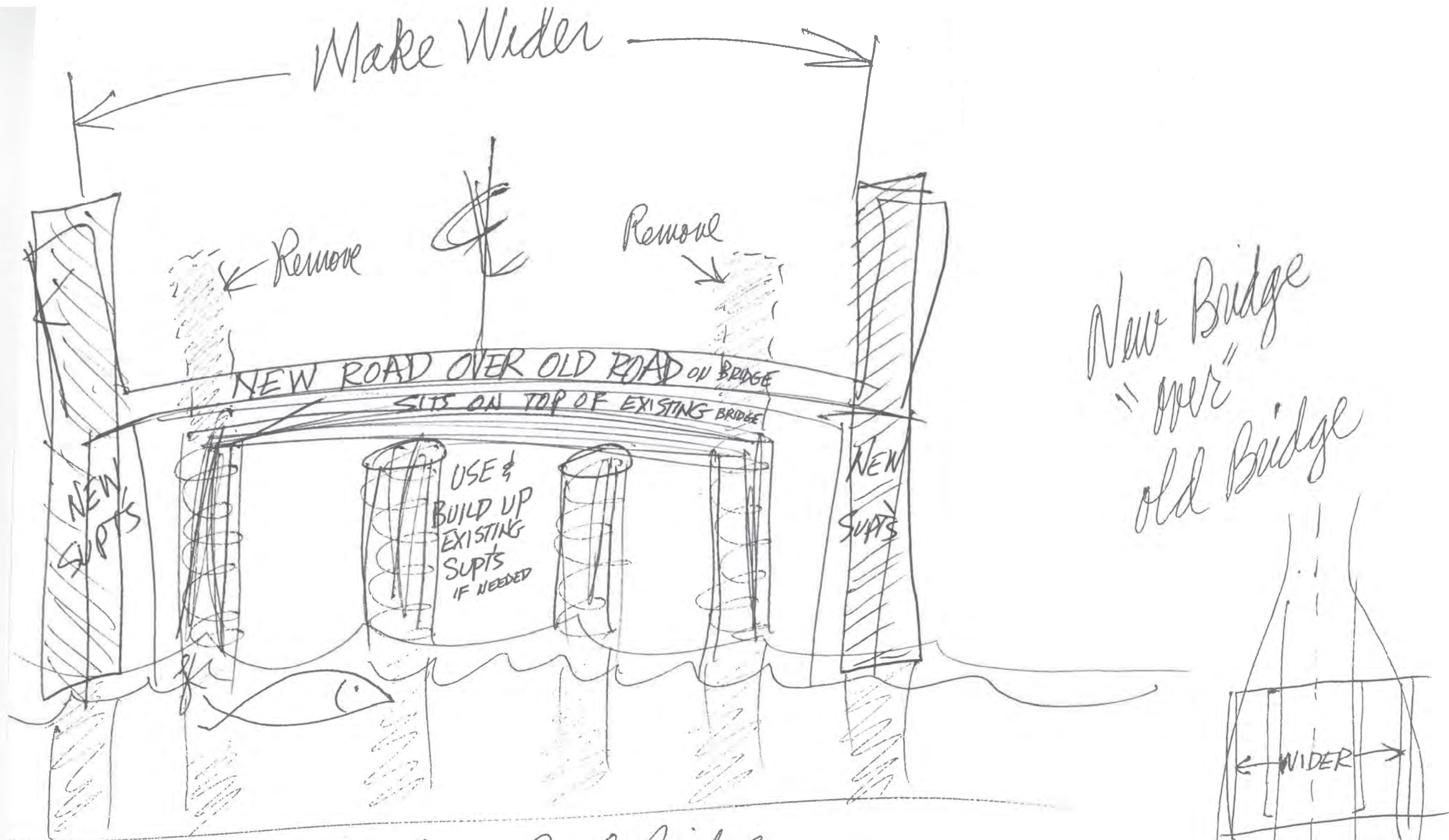

Catfish Creek Road Bridge

Jan. 23, 2024

J

(4x) MINIMUM  
Sand to take  
to raise &  
widen road

## Oujevolk, Richard M.

---

**From:** David LeFort <dajo@embarqmail.com>  
**Sent:** Monday, February 5, 2024 4:12 PM  
**To:** Oujevolk, Richard M.  
**Subject:** Catfish Creek Road Bridge Rehabilitation

[CAUTION: External Message\*]

To: Project Manager Richard 'OJ' Oujevolk

In response to the article in the Highlands News-Sun on January 23, 2024, regarding the Catfish Creek Bridge, I felt compelled as a resident of Placid Lakes for the past 13+ years to reply.

Firstly, having been employed by the Federal Government for several years in different Departments, it would appear that a feasibility study would need to be conducted before making any appropriations as to the requirement for such a project.

To broaden the bridge to add shoulders or sidewalks would not connect them to sidewalks or shoulders exiting Placid Lakes since none exist. Nor will the likelihood lead to construction of them because of a need. Catfish Creek Road has an unlevel grassy shoulder, dangerous to bicyclists and pedestrians alike; not to mention drivers, due to obstructed views because of the hills. Secondly, the width of the bridge has not presented a problem since large trucks traverse it regularly.

In addition, the lengthy time required to complete the project would close down the main route in and out of Placid Lakes into the Town, causing even the school buses to be re-routed, obviously requiring the drivers to plan more time for pickup and dropoff of students.

Then there's the current use under the bridge of the only boat access from the numerous canals to Lake June. Most of those residents purchased property along the canals (paying a higher price for the location) for that purpose. Would a change to the bridge continue to facilitate that accessibility? It appears that the majority of boats housed along the canals are pontoon boats, not able to be transported and launched from the ramp in Tobler Park on the other side of the bridge.

Thank you for your consideration of these comments in making your decision.

Submitted by Joanne L. LeFort

[\*CAUTION: This message originated from outside of the organization. Do not click links or open attachments unless you recognize the sender and know the content is safe.]

## Schooley, Cris

---

**From:** Oujevolk, Richard M. <roujevolk@highlandsfl.gov>  
**Sent:** Wednesday, February 14, 2024 11:29 AM  
**To:** Clogston, Karen V.; Victoria Menchaca; Langford, James D.  
**Cc:** Schooley, Cris; Davis, Josh  
**Subject:** RE: Public Workshop scheduled for Catfish Creek Road Bridge Rehabilitation, FPID No. 446394-1-54-01 & HC Project No. 22061, Highlands County

**Follow Up Flag:** Follow up  
**Flag Status:** Flagged

**Categories:** External

Hi All – I will notify the project team to coordinate with Florida Division of Historic Research in regards to the potential historic and proximity to our work area (essentially the bridge).

Thank you for the information.

Happy Valentine's Day!  
OJ

---

**From:** Clogston, Karen V. <kclogston@highlandsfl.gov>  
**Sent:** Wednesday, February 14, 2024 10:10 AM  
**To:** Victoria Menchaca <VictoriaMenchaca@semtribe.com>; Oujevolk, Richard M. <roujevolk@highlandsfl.gov>; Langford, James D. <jdlangford@highlandsfl.gov>  
**Subject:** Re: Public Workshop scheduled for Catfish Creek Road Bridge Rehabilitation, FPID No. 446394-1-54-01 & HC Project No. 22061, Highlands County

Thank you Ms. Menchaca. I have copied Engineering staff on this reply so they are made aware of your information. Have a good day,  
Karen



**Karen Clogston, APIO**

Public Information Officer

Highlands County Board of County Commissioners

863-402-6636

[kclogston@highlandsfl.gov](mailto:kclogston@highlandsfl.gov)

[www.highlandsfl.gov](http://www.highlandsfl.gov)



600 S. Commerce Ave., Sebring FL 33870

DISCLAIMER: Under Florida law, e-mail addresses are public records. If you do not want your e-mail address or mail to this entity. Instead contact this office by phone or in writing (pursuant to Section 668.6076, Florida Statutes).

---

**From:** Victoria Menchaca <[VictoriaMenchaca@semtribe.com](mailto:VictoriaMenchaca@semtribe.com)>  
**Sent:** Wednesday, February 14, 2024 10:01 AM  
**To:** Clogston, Karen V. <[kclogston@highlandsfl.gov](mailto:kclogston@highlandsfl.gov)>  
**Subject:** Re: Public Workshop scheduled for Catfish Creek Road Bridge Rehabilitation, FPID No. 446394-1-54-01 & HC Project No. 22061, Highlands County

[CAUTION: External Message\*]

Good Morning,

Thank you for the information and the quick response. Although there is no federal nexus for us to review, I would suggest that Highlands County check with the Florida Division of Historic Resources. According to our database there is a previously recorded archeological site that has not had an official evaluation by the state located near the bridge.

Sincerely,

Victoria L. Menchaca, MA, Compliance Analyst II

STOF THPO, Compliance Section

30290 Josie Billie Hwy, PMB 1004

Clewiston, FL 33440

Fax: 863-902-1117

Email: [victoriamentchaca@semtribe.com](mailto:victoriamentchaca@semtribe.com)

---

**From:** Clogston, Karen V. <[kclogston@highlandsfl.gov](mailto:kclogston@highlandsfl.gov)>  
**Sent:** Tuesday, February 13, 2024 4:17 PM  
**To:** Victoria Menchaca <[VictoriaMenchaca@semtribe.com](mailto:VictoriaMenchaca@semtribe.com)>  
**Subject:** Re: Public Workshop scheduled for Catfish Creek Road Bridge Rehabilitation, FPID No. 446394-1-54-01 & HC Project No. 22061, Highlands County

[CAUTION: This email originated from outside of the organization. Do not click links or open attachments unless you recognize the sender and know the content is safe.]

Hello Ms. Menchaca,

Here are the answers to your questions:

- Will your proposed project be subject to the Section 106 National Historic Preservation Act review process? **NO** That is: 1). A project carried out by or on behalf of a federal agency; **NO** 2) A project

carried out with federal financial assistance (e.g., via FDOT and the Federal Highways Administration); **NO** 3) A project requiring a federal permit, license or approval; or 4) A project subject to state or local regulation administered pursuant to a delegation or approval by a federal agency. **NO, this project is State funded only (grant from FDOT with State funds only) for repairs to the bridge proper. All improvements are for safety and structural reinforcement to the bridge and will all be accomplished within the existing ROW on the existing bridge.**



**Karen Clogston, APIO**

Public Information Officer

Highlands County Board of County Commissioners

863-402-6636

[kclogston@highlandsfl.gov](mailto:kclogston@highlandsfl.gov)

[www.highlandsfl.gov](http://www.highlandsfl.gov)



600 S. Commerce Ave., Sebring FL 33870

DISCLAIMER: Under Florida law, e-mail addresses are public records. If you do not want your e-mail address published, please do not email to this entity. Instead contact this office by phone or in writing (pursuant to Section 668.6076, Florida Statutes).

---

**From:** Victoria Menchaca <[VictoriaMenchaca@semtribe.com](mailto:VictoriaMenchaca@semtribe.com)>

**Sent:** Monday, February 12, 2024 5:10 PM

**To:** Clogston, Karen V. <[kclogston@highlandsfl.gov](mailto:kclogston@highlandsfl.gov)>

**Subject:** RE: Public Workshop scheduled for Catfish Creek Road Bridge Rehabilitation, FPID No. 446394-1-54-01 & HC Project No. 22061, Highlands County

[CAUTION: External Message\*]

Good Afternoon Karen,

We received this public notice and wanted to request the following information:

- Will your proposed project be subject to the Section 106 National Historic Preservation Act review process? That is: 1) A project carried out by or on behalf of a federal agency; 2) A project carried out with federal financial assistance (e.g., via FDOT and the Federal Highways Administration); 3) A project requiring a federal permit, license or approval; or 4) A project subject to state or local regulation administered pursuant to a delegation or approval by a federal agency.

Sincerely,

Victoria L. Menchaca, MA, Compliance Analyst II  
STOF THPO, Compliance Section

30290 Josie Billie Hwy, PMB 1004  
Clewiston, FL 33440  
Fax: 863-902-1117  
Email: [victoriamenchaca@semtribe.com](mailto:victoriamenchaca@semtribe.com)

---

**From:** Clogston, Karen V. <[kclogston@highlandsfl.gov](mailto:kclogston@highlandsfl.gov)>  
**Sent:** Tuesday, January 23, 2024 12:10 PM  
**To:** Clogston, Karen V. <[kclogston@highlandsfl.gov](mailto:kclogston@highlandsfl.gov)>  
**Cc:** Langford, James D. <[jdlangford@highlandsfl.gov](mailto:jdlangford@highlandsfl.gov)>; DeFronzo II, Joseph L. <[jdefronzo@highlandsfl.gov](mailto:jdefronzo@highlandsfl.gov)>; Linsinbigler, Vickey <[vlinsinbigler@highlandsfl.gov](mailto:vlinsinbigler@highlandsfl.gov)>; Howerton Jr, Clinton <[chowerton@highlandsfl.gov](mailto:chowerton@highlandsfl.gov)>; Willis, Jennifer <[jwillis@highlandsfl.gov](mailto:jwillis@highlandsfl.gov)>; Culpepper, Melony <[mculpepper@highlandsfl.gov](mailto:mculpepper@highlandsfl.gov)>; Attinger, Philip <[pattinger@highlandsfl.gov](mailto:pattinger@highlandsfl.gov)>; Oujevolk, Richard M. <[roujevolk@highlandsfl.gov](mailto:roujevolk@highlandsfl.gov)>  
**Subject:** \*\*\*DO NOT REPLY ALL\*\*\* Public Workshop scheduled for Catfish Creek Road Bridge Rehabilitation, FPID No. 446394-1-54-01 & HC Project No. 22061, Highlands County

**CAUTION:** This email originated from outside of the organization. Do not click links or open attachments unless you recognize the sender and know the content is safe.

Highlands County invites you to a Public Workshop for the Catfish Creek Road Bridge Rehabilitation Project along Catfish Creek Road over Catfish Creek.

This project will evaluate potential improvements to address existing structural maintenance requirements, as well as identify needs for enhancing safety, accommodating pedestrians and bicyclists, and meeting future transportation demand. **Please see the newsletter attached to this email.**

The Public Workshop is being conducted to involve the public, local officials, and interested agencies in the project development process and to inform interested parties of the project's current status.

**IN-PERSON WORKSHOP:**

Tuesday, February 20, 2024

6:30 p.m. – 8 p.m. open house

Placid Lakes Home & Property Owners Association Clubhouse

2010 Placid Lakes Blvd

Lake Placid, FL 33852

**If you are unable to attend the meeting,** comments can also be provided by email ([ROujevolk@HighlandsFL.gov](mailto:ROujevolk@HighlandsFL.gov)) or mail (Highlands County Engineering, Attn: Richard "OJ" Oujevolk, 505 South Commerce Ave, Sebring, FL 33870). While comments about the project are accepted at any time, they must be

received or postmarked by March 1, 2024, to be included in the formal workshop record. Questions can be answered by emailing the Highlands County project manager Richard "OJ" Oujevolk at [ROujevolk@HighlandsFL.gov](mailto:ROujevolk@HighlandsFL.gov).

Highlands County is sending notices to property owners, business owners, interested persons and organizations within 300 feet of the project to provide the opportunity to give comments regarding this project (*see the attached newsletter*).

Public participation is solicited without regard to race, color, national origin, age, sex, religion, disability or family status. Persons who require special accommodations under the Americans with Disabilities Act should contact Sherri Bennett, Highlands County ADA Coordinator, by phone at (863) 402-6509 or by email at [HRManager@HighlandsFL.gov](mailto:HRManager@HighlandsFL.gov) at least five (5) days prior to the meeting. Persons who require translation services (free of charge) should contact Emanuelle Rodriguez at (386) 271-0273 or email at [emanuelle.rodriguez@kimley-horn.com](mailto:emanuelle.rodriguez@kimley-horn.com) at least five (5) days prior to the meeting.

## Schooley, Cris

---

**From:** Oujevolk, Richard M. <roujevolk@highlandsfl.gov>  
**Sent:** Wednesday, February 14, 2024 11:32 AM  
**To:** Schooley, Cris; Davis, Josh  
**Cc:** Langford, James D.; DeFronzo II, Joseph L.; Harrison, Jonathan  
**Subject:** FW: Catfish Creek Road Bridge Meeting Feb. 20, 2024  
**Attachments:** Catfish Creek Bridge Project.docx

**Categories:** External

Hi Cris/Josh – see attached and below. Probable questions in regards to Catfish Creek. I will hopefully reduce some of them by my opening remarks.

Happy Valentine's Day!  
OJ

---

**From:** DAVID SHUMAN <dshuman161@comcast.net>  
**Sent:** Wednesday, February 14, 2024 10:29 AM  
**To:** Oujevolk, Richard M. <roujevolk@highlandsfl.gov>  
**Cc:** Harrison, Jonathan <jharrison@hcbcc.org>; gregdunlop13@gmail.com; John D Purcell <jpur2000@gmail.com>; jmann0518@gmail.com; Fran Bearden <ftbearden3@icloud.com>; mlprice@bellsouth.net; Tim Donoho <timdonoho1970@gmail.com>; Betty Hardy <bhlp@embarqmail.com>; Connie Luke rockymtnsunshine@aol.com <rockymtnsunshine@aol.com>; debimull1953@gmail.com; ccrossett@hotmail.com  
**Subject:** Catfish Creek Road Bridge Meeting Feb. 20, 2024

[CAUTION: External Message\*]

Please find attached some talking points for the Catfish Creek Road Bridge rehabilitation meeting to be held on Tuesday, Feb. 20 at the Placid Lakes Community Center.

There may be additional questions arise, but this may help you better prepare for the meeting.

Brad Shuman  
Placid Lakes HOA

[\*CAUTION: This message originated from outside of the organization. Do not click links or open attachments unless you recognize the sender and know the content is safe.]

## Oujevolk, Richard M.

---

**From:** John D Purcell <jpur2000@gmail.com>  
**Sent:** Friday, February 23, 2024 7:48 PM  
**To:** Oujevolk, Richard M.  
**Subject:** Catfish Creek Bridge

**Follow Up Flag:** Follow up  
**Flag Status:** Flagged

[CAUTION: External Message\*]

Dear Mr. Oujevok,

Thank you for you and your team taking time to update us on the Catfish Creek Bridge in Placid Lakes. The meeting went well but the outcome was different than most people expected. You gave us facts based upon reality and I think most of the people now understand that reality.

I have been a full time resident of Placid Lakes for over 7 years and have owned property for 10 years. I am also a Board Member of The Placid Lakes Home & Property Owners Association. The bridge has always been a concern. So now we must plan for what will be best for the community in 25 years in regards to a bridge and the Multi-Pathway. One of my reasons to locate to Placid Lakes was the small town atmosphere and laid back community. I and others are realizing that growth will change what we have admired about this community, whether that will be good or bad we will have to wait and see.

In looking at your proposals for the "Future Bridge Replacement" (Unfunded) I see no reason to have two sidewalks on the bridge. There is only one sidewalk on Catfish Creek Rd on the Northside of the road that ends at Tobler Park. The projected multi-pathway will be on the South side of Catfish Creek Rd and end on the East side of Catfish Creek. Therefore, there is only need for one sidewalk connecting the two sidewalks and to handle pedestrian and bike traffic that cross the bridge. I feel two sidewalks would be a waste of money. Which side of the bridge the sidewalk is on would depend upon what side of Catfish Creek it is determined to be best to cross over from the Multi-pathway on the South side of Catfish Creek Rd to the current sidewalk on the Northside of Catfish Creek Rd. So the cross over will either be on the East side of Catfish Creek or the Westside of Catfish Creek. You will also need to consider a very visible crosswalk to make crossing Catfish Creek Road safe for pedestrians.

The issue then becomes, if the multi-pathway is completed within 5 years and the new bridge will not be completed in 25 years or more, there is the problem that pedestrians using the multi-pathway will have to cross over Catfish Creek using the existing bridge for 20 years or more, on a bridge that is not safe for pedestrian traffic now and surely not in the next 25 years as the traffic on the bridge of both vehicles and pedestrians is expected to increase considerably.

Therefore, I believe, Alternative 1 makes the most sense, **IF**, the "Pedestrian Bridge by Others" can be completed as part of the Multi-pathway. However, I don't think a fully enclosed "Pedestrian Bridge by Others" is necessary. What would need to be determined is what side of the current bridge the "Pedestrian Bridge by Others" would be built and how high it needs to be to allow for boat traffic underneath, so that when the new bridge is built in the future, the Pathway Bridge will already be at the proper height.

In regards to the height of the bridge, personally I don't think it needs to be tall enough for a fishing boat with a "T" top; however, it should be high enough for a pontoon boat with its Bimini top up. I think you will find very few people that

live on the canals would have or need a large fishing boat to use on Lake June, but the vast majority of boats that go under the bridge will not be larger than a pontoon boat.

I hope you take my comments into consideration as to the future of the bridge and the Placid Lakes community.

Respectively,

John D Purcell

Make it a Great Day!

ODAAT

614-580-7514

**[\*CAUTION:** This message originated from outside of the organization. Do not click links or open attachments unless you recognize the sender and know the content is safe.]

## Oujevolk, Richard M.

---

**From:** Elaine Thering <bthering1952@gmail.com>  
**Sent:** Wednesday, February 21, 2024 11:14 AM  
**To:** Oujevolk, Richard M.  
**Subject:** Placid Lakes Bridge

[CAUTION: External Message\*]

Good morning

Thank you for the presentation last evening on the bridge status in Placid Lakes. You did an excellent job and I do not envy your position at these meetings.

After the meeting I spoke to Josh about the particulars of the new bridge and would offer these comments.

The pedestrian walkway.

There was some concern that if it was put in place prior to the new bridge, it would just be in the way when the bridge was replaced. An alternative might be to place a steel truss walkway at the extreme southern edge of the right of way. This would keep it out of the bridge construction, and it could be removed at the project completion. If a spread footing and steel columns were used instead of a controlled fill, the cost to install and remove it would be far less. The approach from both sides of the span could also be truss walkways, landed on their own spread footings.

The span of the replacement bridge.

I was told that at this point the replacement members are to be prestressed concrete with a section depth of 36". When this is added to the new deck height you are nearly 4' thick. I don't understand the new span requirement of 120 feet. This will make the approaches prohibitively long, causing their own additional problems. Why not consider keeping the span at the approximately 65' that it is now and utilize a row of piers at mid span. These piers would provide a "lane" structure for the passing boats as well as decreasing the section depth of the span members. The 65' reduced span alone would probably reduce the section depth and that would certainly help with the approach problems.

Setting up a stop light to control the traffic at the bridge.

I believe that the majority of the attendants would not like this idea because of personal inconvenience. I don't like the lights for a more subtle reason. With lights the traffic will be slowed as the drivers become frustrated. Since it is slower, fewer people will choose to go that way, lowering the daily count. If the traffic count diminishes the urgency of the bridge replacement will suffer. A benefit may be that the large truck traffic would probably go down.

Just my thoughts.

Please acknowledge receipt of this Email just so I know it went through.

Bill Thering  
234 Cumquat Rd. NE  
Lake Placid

**[\*CAUTION:** This message originated from outside of the organization. Do not click links or open attachments unless you recognize the sender and know the content is safe.]

## **APPENDIX D**

### SHPO Correspondence



AR=1  
SS=0  
CM=0  
RG=0  
BR=0  
Total=1

## Cultural Resource Roster

SiteID	Type	Site Name	Address	Additional Info	SHPO Eval	NR Status
HG00712	AR	CATFISH CREEK	LAKE PLACID			

